

Door and Gate Operators



Introduction
Summary of Available Operators **Page 04.003.00**
Compliance with Standards



DICTAMAT *MultiMove*
Operating System **Page 04.011.00**
with Separate Control System

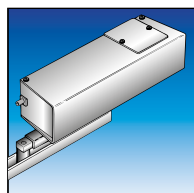

Operators for
Sliding and Hinged Doors/Gates **Page 04.027.00**
Range AC-21
with Separate Control System

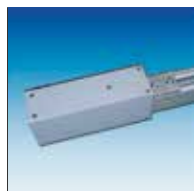

DC-Operators for
Sliding and Hinged Doors **Page 04.045.00**
with Integrated Control System
DICTAMAT OpenDo, SPR

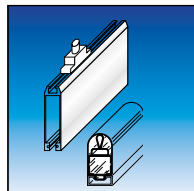

Safety and Operating
Equipment **Page 04.055.00**



DICTATOR Door Operators
Customized Designs **Page 04.075.00**

Door and Gate Operators

Dear customer,

In this register you will find operating solutions for doors and gates. Special operators for fire protection doors/gates you will find in the separate register Fire Door Operators.

For every application we will elaborate a **complete solution**, considering the relevant standards and your requirements. Please contact our technical department.

We would be happy to send you further information and CAD diagrams of the operators in question. Please just let us know.

This catalog contains plenty of detailed data about many of our products. Although we have carefully checked all the information we cannot guarantee that this catalog contains no mistakes and take no responsibility for the correctness of the data/details provided.

Certain details of all technical products - even when they are manufactured very accurately - have tolerances.

Please note that all measurements (unless stated otherwise) are in inch, pound, pound force etc. As the measurements have been converted from metric numbers, the numbers are nearly always odd numbers.

Technical changes may happen and are not subject to notice.

We appreciate your interest and promise to furnish you immediately with detailed information to any of our other products by fax, email or letter post.

DICTATOR is well known worldwide for its close personal contact to his customers.

We want to become your partner, too.

Management
DICTATOR U.S., Inc.

State February 2021

Dictator Door Operators for Sliding and Hinged Doors

For decades Dictator has been specializing in the design and production of door operators, especially for the **commercial and industrial sector**.

The tables on the following pages will help you to select the right door operator for your door. In addition we also supply custom-built solutions and a large range of door operators for fire protection doors.

Dictator offers

- **door operators to automate doors**, including cold store doors.
- a large standard range of **modular** based and therefore very flexible **door drives**, that can also be adapted to suit special requirements.
- **customized door operators** (e.g. for multi-media facilities, very large and heavy doors, heavy overhead doors, hazardous areas and so on).
- the use of **CAD to facilitate and speed up installation** (very important e.g. in case of restricted space: the exact placing of the operator is shown in the door drawing).
- extensive **advisory service, installation** (on demand), **maintenance, service, training seminars**.

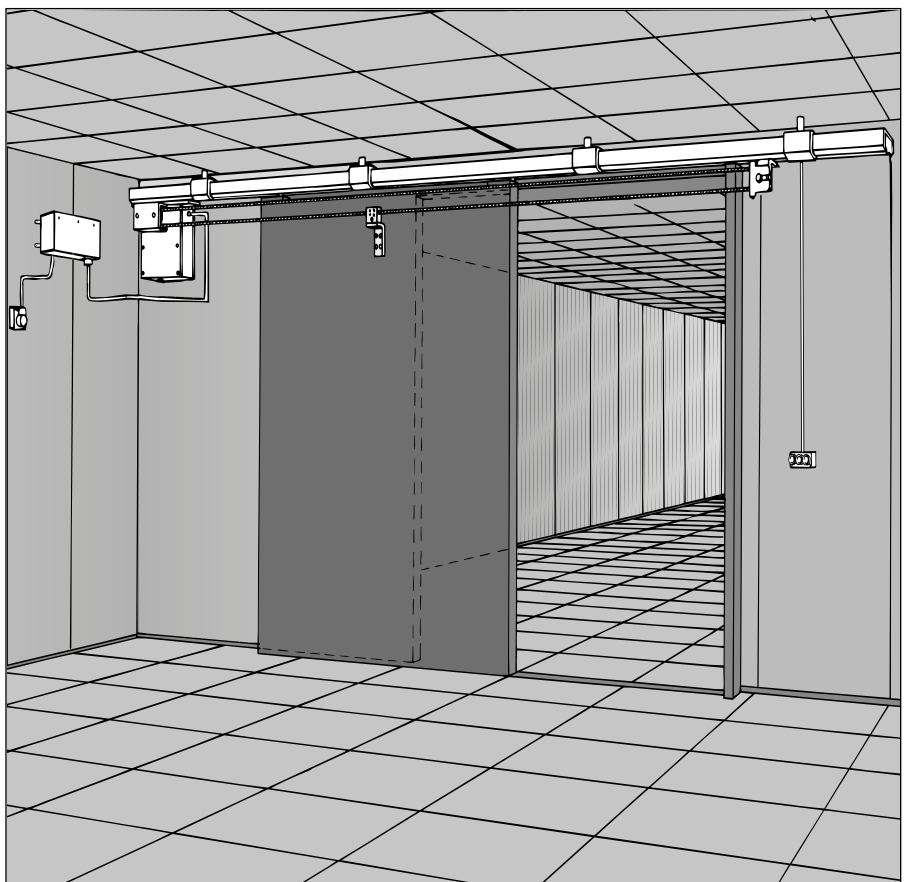

Technical Data

DC door operators with integrated encoder

DC door operators with limit switches

Three-phase-current (AC) door operators with integrated encoder

Three-phase-current (AC) door operators with separate limit switches

Customized door operators

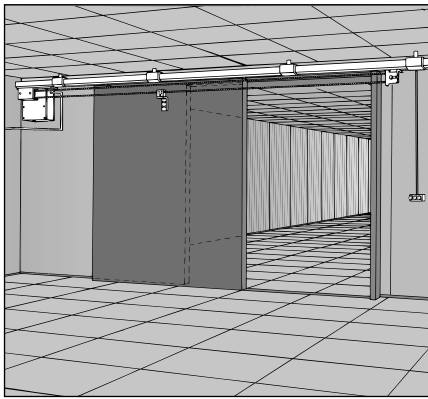

DICTATOR Door Operators - Summary

DICTATOR offers you a **standard program** of different door operators to automate your doors.

In addition we provide **customized designs**, for example for very large and heavy doors, for multi-media facilities, door or window installations with little space to house the operators, door operators for complex processing requirements. Amongst our customers for the customised designs are the Corte Inglés (shopping centres in Spain), the Madrid Airport, Hermès (Hermès building in Tokio).

1. Door Operators for Sliding Doors

The DICTATOR door operators DICTAMAT for sliding doors are used in very different applications, however mainly in the **industrial and commercial sector**. To this belong also sliding doors in the **plant engineering and machine construction** as well as for **cold stores**.

The DICTATOR product range provides DICTAMAT door operators for different door sizes and weights, normally with integrated position control. The power transmission is effected mostly either by revolving toothed belt or chain. The choice of the appropriate door operator is influenced by the question whether the complete door installation has to meet the requirements of the EN 13241-1 and **EN 12453**.

For hazardous locations DICTATOR offers **explosion-proof** three-phase-current **door operators**. Here we need the required degree of protection and the information where the control system is installed: inside or outside the hazardous area.

On **page 04.015.00** you will find an **overview of the operators** of the DICTAMAT *MultiMove* range. On page 04.028.00 are given values for the DICTAMAT 900-21 series with three-phase current motors. But the easiest way would be to let us elaborate the appropriate operating solution for your project - of course free of charge.

2. Door Operators for Hinged Doors

The DICTAMAT door operators for hinged doors are as well mainly used in the industrial and commercial sector. Some of the door operators open the doors up to 180°.

DICTATOR offers also for hinged doors customized solutions, e.g. for very large and heavy hinged doors.

Operator model	Opening		Closing		Door width	Operator power	Opening angle	Special features
	Motor	Spring	Motor	Spring	max.		max.	
DICTAMAT 310 (page 04.041.00)	x		x		4.92 ft	max. 147.5 lbf ft	180°	SQUARE 940-2 control system
DICTAMAT 310 XXL (page 04.041.00)	x		x		8.2 ft	max. 516.3 lbf ft	180°	SQUARE 940-2 control system
Customized operators: three-phase current up to 0.37 kW DC	x		x					upon request



DICTATOR Door Operators - Compliance with Standards

The Machinery Directive 2006/42/EG and the related standards extremely affect doors and gates. As soon as a door is equipped with an door operator, it becomes a "machine". It is mandatory that the automated door complies with the Machinery Directive.

The "manufacturer" of the machine, i.e. the company who mounts the operator on the door, is obliged to issue a CE declaration of conformity for the "machine door". For this reason it is very important that the used door operators comply with the demands of the Machinery Directive respectively facilitate its compliance.

1. Relevant Standards for Automated Doors/ Gates

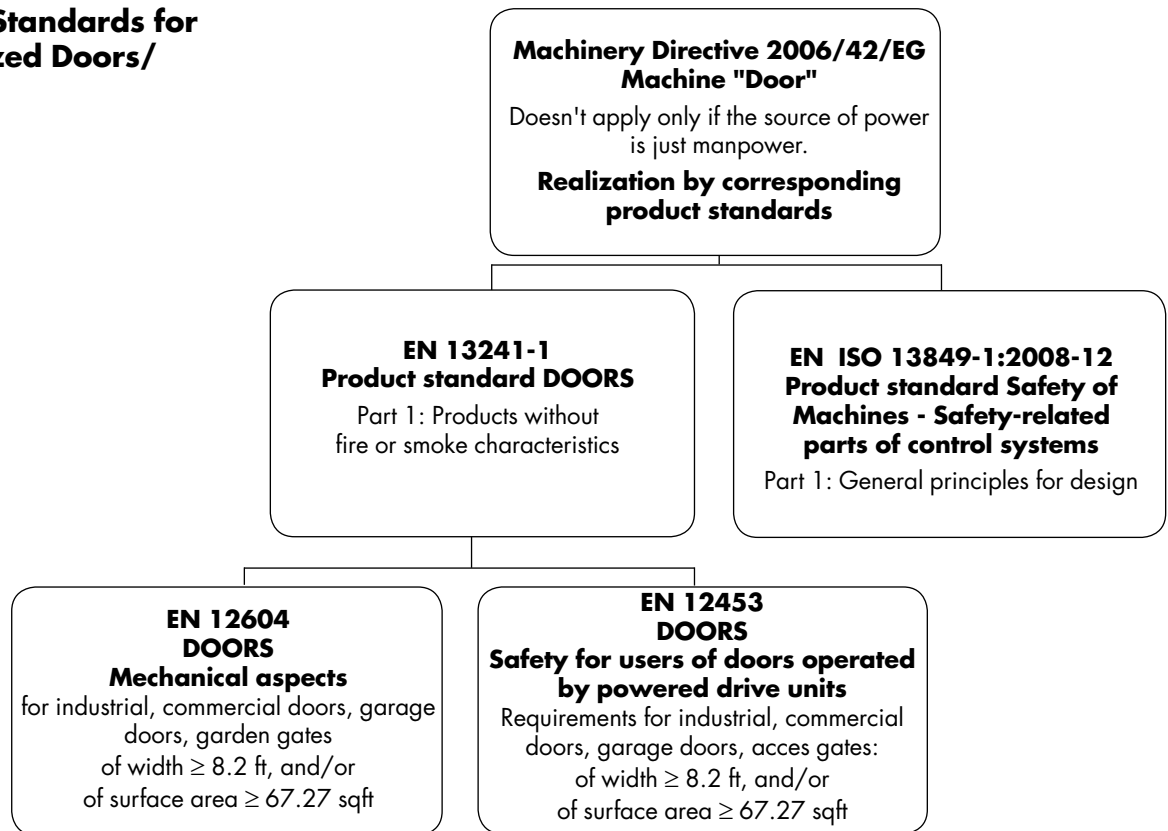

2. Definition of "Door" according to EN 13241-1

The standard EN 13241-1 applies to doors..., which are intended to be used by people in access areas and whose main purpose is to allow for a safe access of goods and vehicles being accompanied or conducted by people in industrial, commercial or living areas.

To the following doors/gates the standard EN 13241-1 does **not** apply:

- Fire protection doors, doors in emergency exits
- Lift doors
- Doors for pedestrians moved horizontally by hand with a surface area of less than 67.27 sqft
- Horizontally motor driven doors with a width of less than 8.2 ft and a surface area of less than 67.27 sqft, intended mainly for pedestrians
- Doors used mainly for animals
- Vehicle doors, textile theatre curtains etc.



Dictator Door Operators - Compliance with Standards, cont.

The standard EN 12453 (see previous page) defines the specifications of power driven doors, its main intention being the general increase of safety. It focuses on the following four points.

3. Main Safety Requirements to Motor Operated Doors

a) Preventing the danger (of squeezing, shearing, feeding and collision) by the automatized door.

b) Stopping the door within the following distances:

- Door opened 19.69" at the most slowing-down path ≤ 1.97"
- Door opened more than 19.69" slowing-down path ≤ 3.94"

c) Limitation of force

The force developing when the door hits a person, has to be reduced within a certain time to a not dangerous dimension (see force diagram).

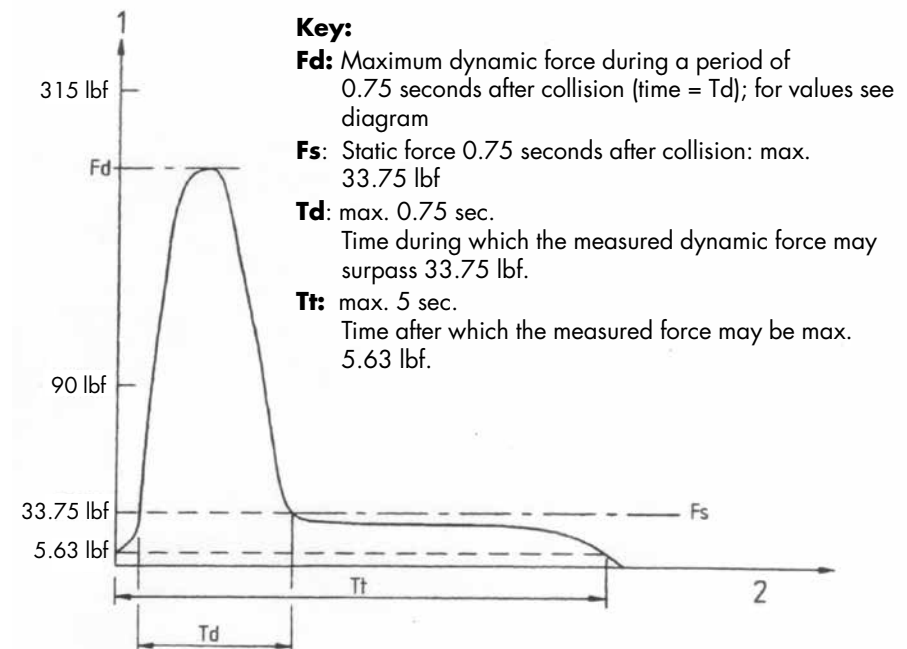

Maximum dynamic force (**Fd**) allowed between both closing edges:

Opening width	1.97 - 19.69"	> 19.69"
	90 lbf	315 lbf

d) Single error safety/Redundancy

In case an error occurs in one of the elements of the installation which could cause a dangerous situation, the control system has to recognize this and to shut down the complete system. The fault has to be remedied before the door may be power operated again.



DICTATOR Door Operators - Compliance with Standards, cont.

To meet the requirements of the standard EN 12453 to increase safety several measurements are combined. The safety installations used have to comply with much higher standards as well as the construction of the door drives has to be improved accordingly.

With regard to the safety devices the EN 12453 still refers to the old standard EN 954-1. In the meantime the EN 954-1 has been replaced by the standard EN 13849-1:2008-12. However, the standard EN 12453 has not been changed!

4. Approaches

a) Preventing squeezing, shearing, feeding or collision

Depending on the chosen/allowed mode of operation different minimum protections of the door are necessary.

Possible operation modes:

- **Dead man operation**

Handling only by instructed persons.

When moving the door it has to be possible to oversee the complete area.

- **Impulse/Automatic operation**

Alternative 1:

a) Safeguarding by safety distances at the secondary closing edges.

b) Protection of the main closing edge (obligatory) and of those secondary closing edges where safety distances cannot be observed by restricting forces (see 3/b).

c) Safety installation according to EN 954-1 respectively the subsequent standard EN 13849-1.

d) Additional safety devices in certain dangerous areas.

Alternative 2:

Use of safety devices preventing anybody to get in the range of the moving door.

Application	Domestic sector only instructed users <i>Type 1</i>	Public sector only instructed users <i>Type 2</i>	Public sector no restriction of users <i>Type 3</i>
Door operation mode			
Dead man operation (only allowed when door can be seen)	A	B	not allowed
Impulse operation with sight of the door	C or E	C or E	C + D or E
Impulse operation without sight of the door	C or E	C + D or E	C + D or E
Automatic operation	C + D or E	C + D or E	C + D or E

Key:

A: not holding button

B: not holding key switch

C: Safety device according to EN 954-1, category 2, 3 or 4

D: Safety device (no special requirements)

E: Safety device preventing anybody to get in the range of the moving door (e.g. a light curtain in a sufficient distance to the door)



DICTATOR Door Operators - Compliance with Standards, cont.

According to the Machinery Directive door and operator together form the "machine door". This means that for the whole installation a declaration of conformity has to be handed in. For all doors produced after May 1st, 2005 the manufacturer has to provide the CE sign. In case a door is automatized, a CE declaration of conformity has to be handed in also for the whole installation. Depending on whether there exists already an initial test for this unity or whether it has been upgraded, after automatizing the door there have to be effected several additional tests on site.

4. Approaches - cont.

b) Restriction of the slowing-down path and the maximum force (see point 3/b and 3/c)

DICTATOR door operators according to EN 12453 are designed in a way to stop the doors also without current within the required distances of 3.94" or 1.97".

The new DICTAMAT *MultiMove* operators assure this by using the - in this scope of application - completely novel capacitor technique. Even in case of a power cut the operators are absolutely smooth-running.

Other operating systems usually have to use an electromagnetic clutch or a mechanical cranking device to allow moving the door manually during a power failure.

c) Single error safety / Redundancy

The self-supervision of the control system guarantees that the failure of a component will not result in a dangerous situation. If the control system identifies a mistake, it automatically shuts itself down. Further automatic handling of the gate is not possible. Likewise the safety installations have to be largely self-supervising.

5. Conformity of the Whole Door System

According to the Machinery Directive has to be issued a **declaration of conformity** for the automatized door confirming that the whole system complies with the relevant standards. Mainly, there exist three different situations.

a) In the simplest case the **door (produced after May 1st, 2005)** has already been **type-tested together with the drive unit**. Here issuing a declaration of conformity will be relatively easy.

b) In case the DICTATOR door operator is **retrofit** to a door for which together with the door operator exists **no type-test**, there are two possibilities:

- If **for the door itself already exists a conformity declaration** (door complies with EN 13241-1 and EN 12604), the complete installation has to be tested thoroughly according to EN 12445. These tests also include the door where has to be verified especially if it will withstand the higher strain of automatization. Having passed all tests successfully the declaration of conformity will be issued.

- In case of a door having been installed **before May 1st, 2005** and **not having a CE label** firstly you have to verify if the gate meets the requirements of the standards EN 13241-1 and EN 12604. This should normally be executed by door experts. Following this the tests as described above have to be passed.

A door where only an already existing door operator is exchanged will be subject to **preservation of the status quo**. A declaration of conformity has not to be issued.

IMPORTANT: All relevant documents concerning the conformity have to be kept for ten years (where the declaration of conformity has been issued). The operating company has to be instructed thoroughly in using the "machine door". Regular maintenance of the complete door system is stipulated by law.



The EC Machinery Directive 2006/42/EC Its Consequences - Questions and Answers

Often the importance of the Machinery Directive is still underestimated!

DICTATOR elaborates together with you not only the appropriate operating system for your door but also accompanies you on the way from the incomplete machine to the complete one. Already when choosing the door operator we attach special importance to providing the basis for an installation in accordance with the Directives by selecting the appropriate door operator and adapting it to the door.

Applying the Machinery Directive? Why?

- The Machinery Directive has legal force.
- Market surveillance controls more and more often if the directive is observed.
- Not observing the directives can have consequences, e.g.:
 - Prohibition of sale of the product line.
 - Complaints of users/customers.
 - Cost-intensive subsequent improvements.
 - Violation of safety and health demands.
 - Criminal penalties in case of personal injuries.

Manufacturer in Terms of the Machinery Directive

Manufacturer is who:

- produces machines for his own use.
- **Assembles machines or parts of machines**
(e.g. the door manufacturer or the company who upgrades a door with an operator => door + operator + control system = machine door).
- Imports machines.
- Essentially modifies machines by adding components or retrofitting them.

Meaning of the Machinery Directive to Manufacturers of Automated Sliding Doors

Which meaning has the Machinery Directive to manufacturers of automated sliding doors?

- **In terms of the directive a sliding door with a door operator is a machine.**
- The door operator and control system on their own are an incomplete machine.
- The **manufacturer of a machine** is **responsible for the conformity to the directives.**
- Therefore, these manufacturers are obliged to observe regulated conditions during setting up.

Concrete demands to the manufacturer

- The demands of Annex I of the Machinery Directive have to be met (risk evaluation).
- Technical documents (Annex VII) have to be made available.
- Operating instruction has to be provided.
- Conformity evaluation procedure according to article 12 has to be carried out.
- An EC declaration of conformity according to Annex II has to be issued and enclosed with the "machine door".
- The installation has to be labelled with the CE marking according to article 16.



The EC Machinery Directive 2006/42/EC **DICTAMAT MultiMove: the Problem Solver**

The new DICTAMAT *MultiMove* operating system assists the DICTATOR customers even more than other systems in meeting the demands of the Machinery Directive. Thanks to the following points the basis for an installation conform to the directives is provided already **well in advance** of the mounting and thus creating the "machine door".

Effective Structure for an Easy Risk Analysis

The manufacturer of a machine is obliged to operate a risk analysis to achieve the aims of the Machinery Directive.

That is exactly where the **intelligent and effective structure** of the **DICTAMAT MultiMove** comes in useful.

During analyzing the risks of our components we always considered the "machine door", too. It was the crucial factor for designing and the **cooperation of the single components**. This is a big advantage for the manufacturer of a machine door as the DICTAMAT *MultiMove* operating system allows to exclude from the very beginning certain potential sources of injury and health risks. Of course, this is only possible when the system is used for the intended purpose and the operating instructions are observed.

Optimized Technical Documentation

According to the Machinery Directive an incomplete machine requires "only" a mounting instruction. A complete machine, however, requires a complete operation manual. With regard to a **simplified communication** between "manufacturer of the incomplete machine" and "manufacturer of the complete machine" DICTATOR offers for the DICTAMAT *MultiMove* system a complete operation manual. This manual not only directs the assembling without interfering with safety and health but also represents an essential part of the technical documentation of the complete machine.

Conformity

The manufacturer of a machine is obliged to subject the complete machine to a **conformity evaluation procedure**.

The **DICTAMAT MultiMove** easily allows to **meet** this **demand**. Because relevant standards – as e.g. the EN 12453 – have been the signposts already during development. The "incomplete machine operator" meets these harmonized standards which significantly contributes to achieving the "conformity of the machine door".

Individual Adjusting of the Operating and Controlling Unit

Besides these basic advantages the **DICTAMAT MultiMove** operating system offers another important advantage with regard to safety and the conformity to standards:

Each operator and each control system have individually been configured according to your requirements. This represents to the manufacturer of the "complete machine door" not only significant time-savings during setting up, but also maximum safety and thus an important basis for meeting the Machinery Directive.

DICTAMAT MultiMove

The Machinery Directive Compliant Drive Concept

The new operating system DICTAMAT **MultiMove** revolutionizes the door industry. It newly defines user-friendliness and conformity to standards!

- The modular structure offers **extremely high flexibility** and adaptability to customers' requirements.
- The door can be moved manually also during a power failure due to the **absolutely smooth-running gearbox**, no need for an expensive electromagnetic clutch.
- For more safety: **integrated recognition of obstacles with power interruption** also with AC motors.
- **Complies with the demands of the Machinery Directive 2006/42/EG.**

The Machinery Directive imposes a very high responsibility on the "manufacturer of the machine door" i.e. the company who installs an operator on a door. The drive system DICTAMAT *MultiMove* is adjusted already in factory to the respective data of the door. This way the requested stopping distances etc. are met without needing time consuming adjusting on site. This also considerably reduces the laborious approval tests to get the declaration of conformity.

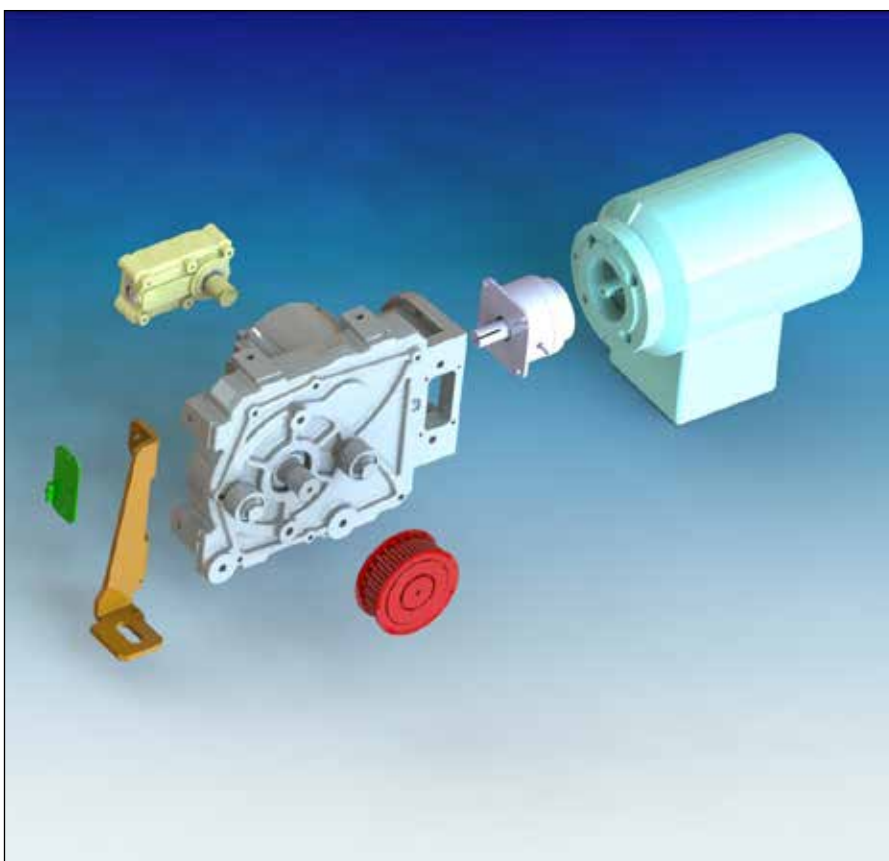

System Components

Gearbox	worm gear with best smooth-running qualities, divers, multi-stage gear ratios possible
Motors	very different motors, DC as well as AC
Power transmission	toothed belt, chain, rack, operating arms for hinged doors/gates etc.
Other components	encoder, dampers for fire protection, hold-open, fixing and mounting accessories etc.
Control system	modular structure with logic unit as basic module, other modules for different motors, fire protection, emergency power supply, special functions etc.



DICTAMAT MultiMove Flexible, Customer-Oriented, Powerful

Decennies of experience with drive technology and in particular with solving special customer requirements influenced the development of the new drive concept DICTAMAT MultiMove. The aim was to offer our customers a drive system which leaves nothing to be desired:

This includes also that the drive concept DICTAMAT MultiMove **meets** the partly extremely high demands of the **Machinery Directive 2006/42/EG**. This facilitates our customers who by mounting a door operator on a door turn it into a "machine", a setting up with the prescribed tests with the least possible effort.

What Moves MultiMove?

The heart of the **DICTAMAT MultiMove** door operators is the **gearbox**. It is extremely smooth-running. And nevertheless meets the demands of the EN 12453 regarding the very short stopping distances in case of a power cut, thanks to the - in this scope of application - novel **capacitor principle**.

This means for the user: **without current doors and gates can easily be moved, without** needing an **expensive additional electromagnetic clutch** or having to manually uncouple the door and later to couple it back again.

The gearbox concept allows thanks to its inner modular structure very different, also multi-stage transmissions, all using the same casing. Therefore, an optimum solution for the most different requirements can always be designed – and with standard components! The decisive advantage: Often it is possible to use a less strong motor which consumes less energy because the modular gearbox makes the optimum use of the motor power.

Furthermore, the gearbox can be combined with any type of **motor**: DC, AC, everything is possible.

Same as the optimized capability the **safety** of the door user, the protection of man and material, is of highest priority to the DICTAMAT MultiMove system:

- A very easy setting up with **automatized teach-in run** nearly eliminates any errors during setting-up and adjusting.
- Intelligent detection of obstacles with **power interruption for AC and DC door operators**.
- **Short stopping distances complying with the standards.**

The **position control** is usually realized by an encoder with very high resolution which allows the exact positioning of the door even with long travels.

The **power** can be **transmitted** either by toothed belt, chain, rack or in case of hinged doors e.g. an operating arm etc.

All operators of the DICTAMAT MultiMove series are controlled by an also **modular structured control system** which can be adapted in an optimum way to the respective application.

The control system is based on a uniform logic unit which is suitable for all operators. All the other criteria as DC or AC motor, fire protection, emergency power supply, special functions are realized by additional modules which can freely be combined with the basic module. Each control system is configured in production for the respective door operator so that the "machine door" meets the demands of the Machinery Directive already to a large extent and when setting up the installation only little adjusting work is left. Therefore, adjusting doesn't take a lot of time and the **costs for mounting and setting up are drastically reduced**.

Furthermore, this control system offers the **possibility to later upgrade the performance and function** - without having to replace the complete control system.

The new DICTAMAT MultiMove drive concept offers **optimum solutions for very differing applications**, assures a **simple, uncomplicated mounting and setting up** and for many years an operation without problems and disturbances.

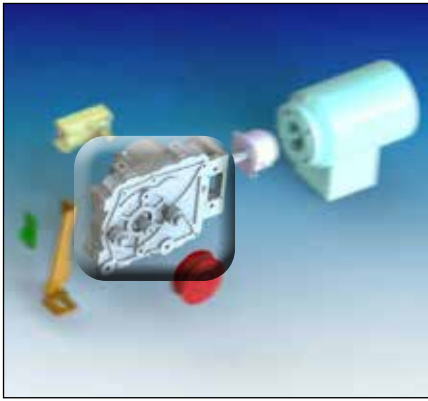

DICTAMAT MultiMove - One Gearbox for All

The gearbox constitutes the heart of the **DICTAMAT MultiMove** drive system. It features **extremely smooth-running** qualities, i.e. in case of a power cut the doors/gates can manually be moved without having to uncouple the door operator. This also represents the indispensable condition for using this system on fire doors. According to the directives effective in Germany, in case of alarm these doors have to be closed mechanically.

DICTAMAT MultiMove Gearbox

The DICTAMAT *MultiMove* gearbox is designed as a worm gear transmission with the possibility of multiple ratio. It consists of a casing from cast aluminium which can contain different reduction stages.

Beside its flexibility the smooth-running properties are its main feature. This also produces a very high degree of efficiency, i.e. the gearbox transmits the motor force without significant losses. Therefore already low motor power will produce high driving forces.

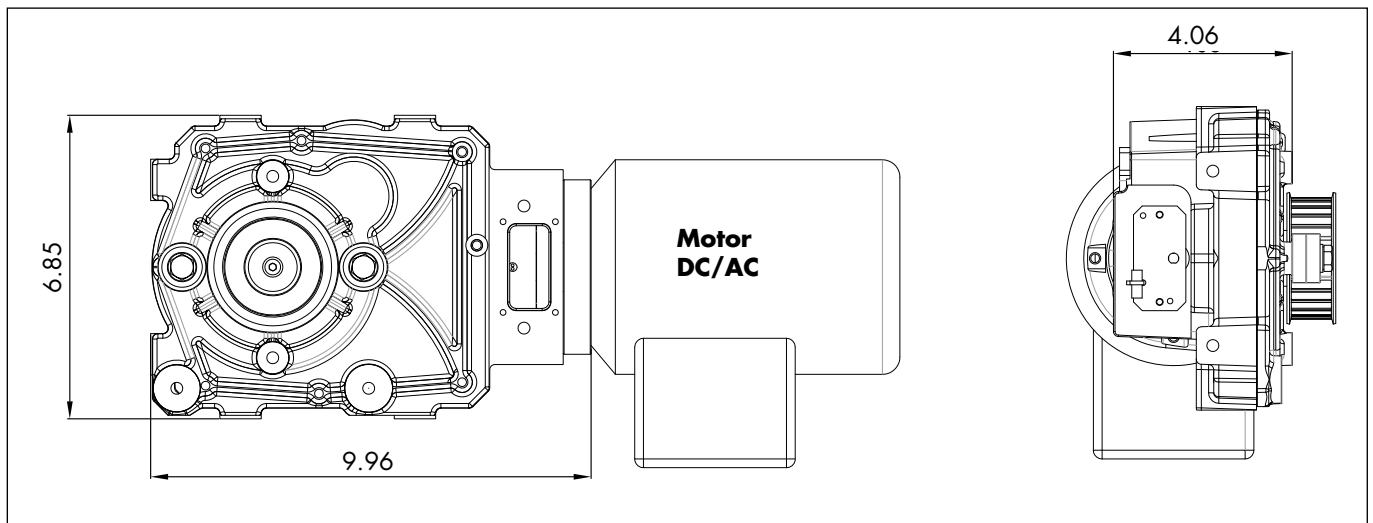

Technical Data

Type of gearbox	worm gear transmission
Gear ratio "i"	20, 27, other transmissions possible on request
Ease of running	example: door weight 1760 lbs force for moving without operator: 13.5 lbf force for moving with operator gearbox i = 20: 18 lbf force for moving with operator gearbox i = 27: 24.75 lbf
Material casing	cast aluminium
Possible motors	DC, AC
Fire protection	during mechanical closing adjustable and controlled closing speed by mounted radial damper LD
Brake	electromagnetic brake, easy-running without current; in case of power cut short-term power supply by capacitor package
Other modules	driving wheel for toothed belt, chain, rack etc.; encoder for position control, hold-open system and speed regulator for fire protection

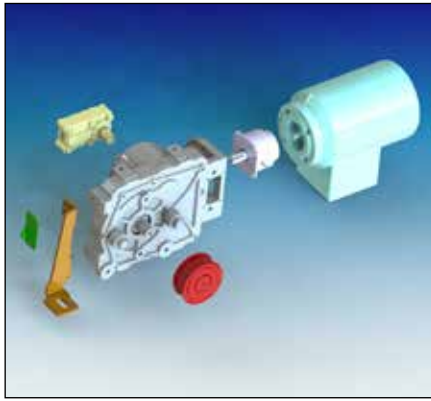

DICTAMAT MultiMove - The System

The modular drive system DICTAMAT *MultiMove* is made up of the respective door or gate operator and the corresponding control system.

Therefore, for an easier identification, the door operators and control systems of the system were assigned a part of the system name:

- Door operator DICTAMAT *Move*
- Control system *Multi Control*

Structure of the Name of the DICTAMAT Move Door Operators

Basically there exist four different versions of the door operators:

- **DICTAMAT Move:** Operators which provide a motor-driven opening and closing of the door/window (**bidirectional door operators**).
- **DICTAMAT Move F:** Operators which **only open** the door/window. Closing is effected by e.g. a counterweight or a spring. In particular in Germany this is prescribed for fire doors. Therefore an "F" (fire protection) is added to the name of this execution.

Note: If the respective country allows closing by emergency power, it is also possible to use bidirectional door operators on fire doors/gates.

- **DICTAMAT Move H:** Door operators for **rotary motions** (hinged doors, hinged gates, hinged windows etc.)
- **DICTAMAT Move C:** all **customized special solutions**.

Other details of the name structure:

Voltage	AC or DC
Electrical power	e.g. 90 W, 0.37 kW
Power transmission	e.g. toothed belt (Z), chain (K), etc. operating arm (H) for hinged doors and gates
Dimensioning of the gearbox	With the same motor can be chosen either the model with higher speed (V+) or higher power (P+).

Example: DICTAMAT *Move* DC 90 Z V+
Bidirectional door operator with direct current motor (**DC**) with **90 W**, power transmission by toothed belt (**Z**), max. 0.37 m/s = 1.21 ft/s (**V+**), power on the belt max. 90 lbf (see next page)

Structure of the Name of the Control Systems *Multi Control*

The control systems of the DICTAMAT *MultiMove* system have a modular structure. Basically there are **three different versions** (independent of the used motor and whether it is a bidirectional or fire protection model):

- **Multi Control Economy:** Model with basic functions
- **Multi Control Comfort:** Model with comfort functions
- **Multi Control Custom:** Model with customized functions that have to be determined in every individual case

Other details of the name structure:

Addition for special functions	F (fire protection), N (emergency power)
Voltage	AC or DC

Example: *Multi Control* Comfort N DC
Comfortable control system for **DC** motor, with emergency power function including battery pack

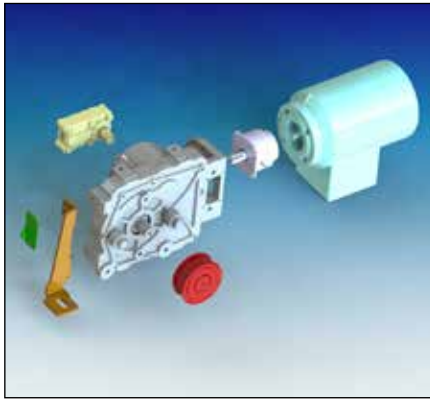

DICTAMAT Move - Summary Operators for Sliding Motions, Bidirectional

On the following pages you will find the **Standard models** of the DICTAMAT Move door operators for **bidirectional sliding motions**. By default they use a revolving toothed belt for power transmission. However, it is also possible to use a chain etc.

The values given in the following table are just for orientation. To meet the demands of the Machinery Directive you should always take advantage of our advisory service and get a detailed offer of the appropriate solution for your application.

Technical Data

Name of DICTAMAT Move	DC 90 Z V+	DC 90 Z P+	DC 200 Z P+	AC 0.18 Z V+	AC 0.18 Z P+	AC 0.37 Z P+
Motor / Gear ratio / Driving wheel	motor DC 90 W, i = 20, Z28	motor DC 90 W, i = 27, Z28	motor DC 200 W, i = 27, Z28	motor AC 0.18 kW, i = 20, Z28	motor AC 0.18 kW, i = 27, Z28	motor AC 0.37 kW, i = 27, Z36
Nominal revolutions/min	1987	1987	2083	1350	1350	1390
(Starting and) / nominal current A	4.72	4.72	11.05	1/0.6	1/0.6	1.8/1.0
Turning moment on the output shaft lbf ft	6.49	8.78	18.29	18.59	25.08	50.89
Power rating W	92	92	200	180	180	370
Max. starting power on the belt lbf	90	135	225	180	225	315
Rated speed inch/sec	14.57	10.63	11.42	9.84	7.48	10.63

Components

- ① Door operator with U-bracket (standard)
- ② Idler pulley with U-bracket (standard)
- ③ Belt fixing device (standard)
- ④ Wall bracket for door operator (optional)
- ⑤ Wall bracket (optional)
- ⑥ Toothed belt (to be ordered separately in the required length and size)
- ⑦ Supporting roller with U-bracket (optional)
- ⑧ Belt fixing device for second door leaf (optional)

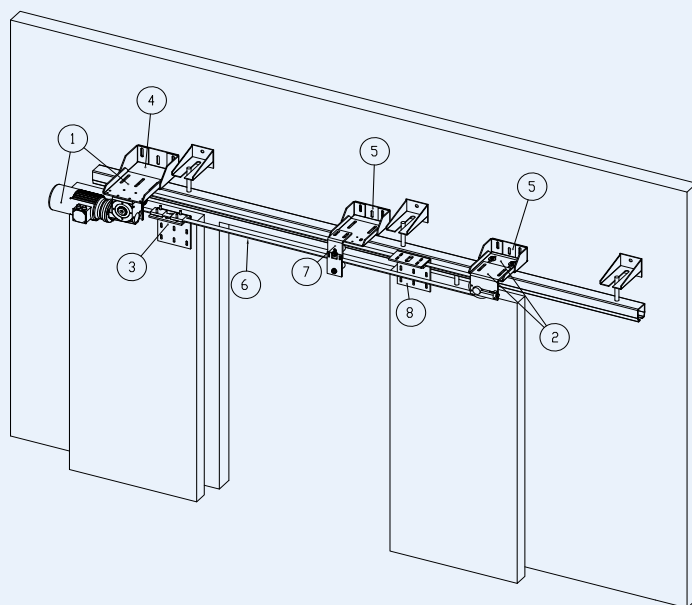

Components Included DICTAMAT Move Z bidirectional

- Motor with gearbox and mounting U-bracket, 6.56 ft of connection cable to control system, driving wheel for toothed belt of 0.79 or 1.18" width, protective guard
- Idler pulley for toothed belt with integrated tensioning device and U-bracket
- Belt fixing device with clamping plates for toothed belt

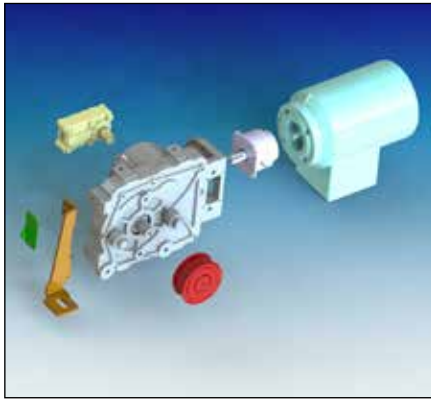

DICTAMAT Move
Dimensions of DICTAMAT Move DC Z (bidirectional)

In the following you will find the dimensions of the standard DC models (bidirectional) for toothed belt. By default, the driving wheel is designed for toothed belt of 0.79" or 1.18" width. Which toothed belt to choose depends on the dimensions of the door, the speed and the working load.

The dimensions of the accessories included in the delivery can be found on page 04.018.00, those of the optional accessories beginning on page 04.019.00.

DICTAMAT Move DC Z



Dimensions
DICTAMAT Move DC 90 Z

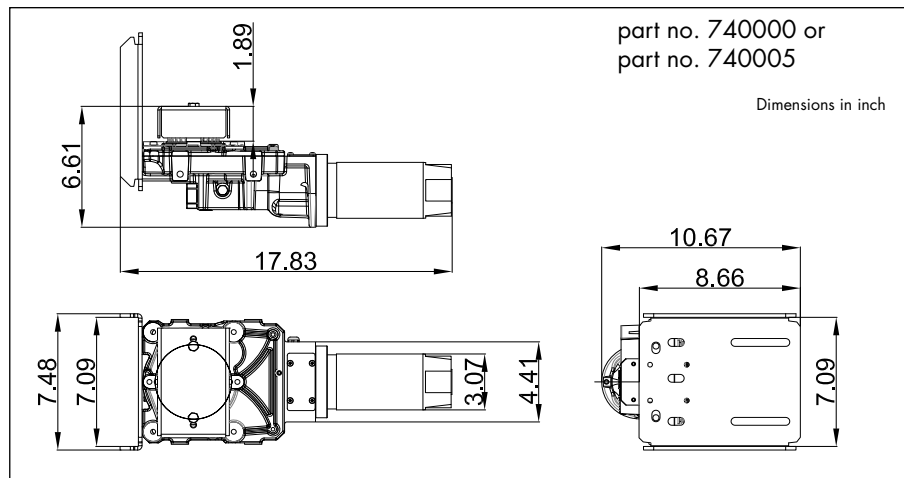

Dimensions
DICTAMAT Move
DC 200 Z

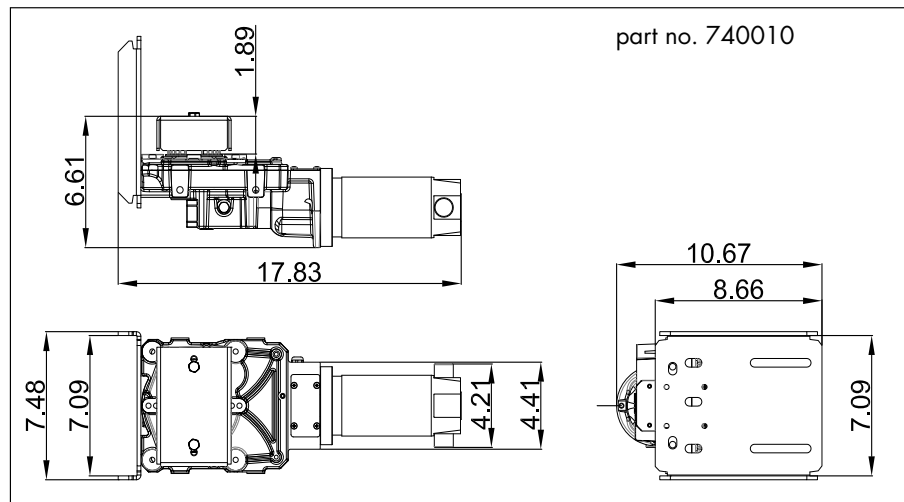



DICTAMAT Move Dimensions of DICTAMAT Move AC Z (bidirectional)

In the following you will find the dimensions of the standard AC models (bidirectional) for toothed belt. By default, the driving wheel is designed for toothed belt of 0.79" or 1.18" width. Which toothed belt to choose depends on the dimensions of the door, the speed and the working load.

The dimensions of the accessories included in the delivery can be found on page 04.018.00, those of the optional accessories beginning on page 04.019.00.

DICTAMAT Move AC Z



Dimensions DICTAMAT Move AC 0.18 Z

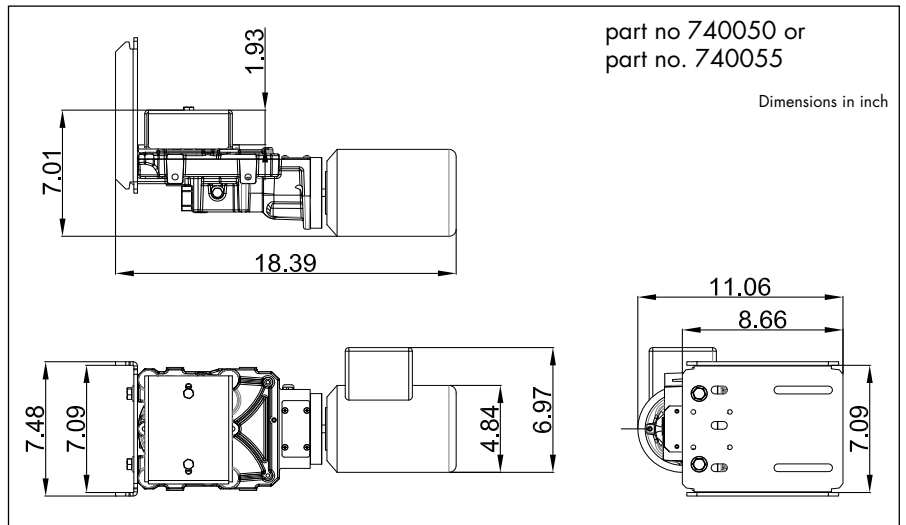

Dimensions DICTAMAT Move AC 0.37 Z

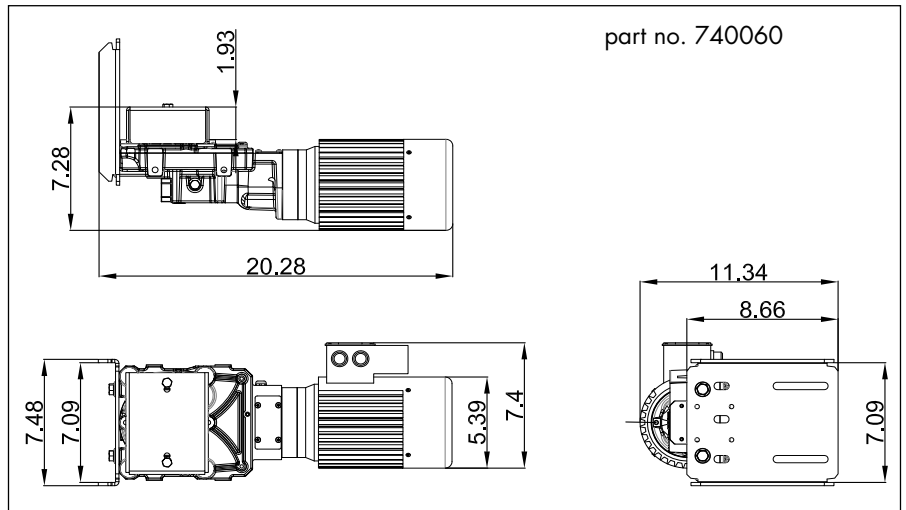

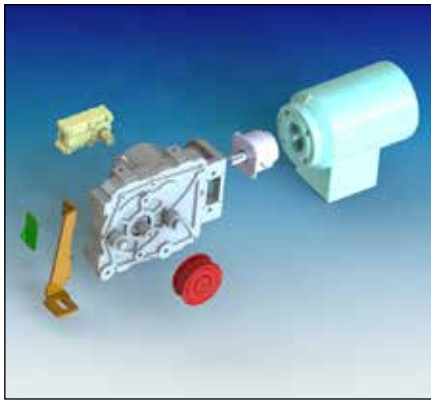

DICTAMAT Move Dimensions of Standard Accessories

By default, the door operator DICTAMAT Move includes an idler pulley and a belt fixing device for toothed belt.

Of the idler pulley exist two versions:

- for DICTAMAT Move DC Z and DICTAMAT Move AC 0.18 Z
- for DICTAMAT Move AC 0.37 Z

Dimensions Idler Pulley with Tensioning Device for Toothed Belt

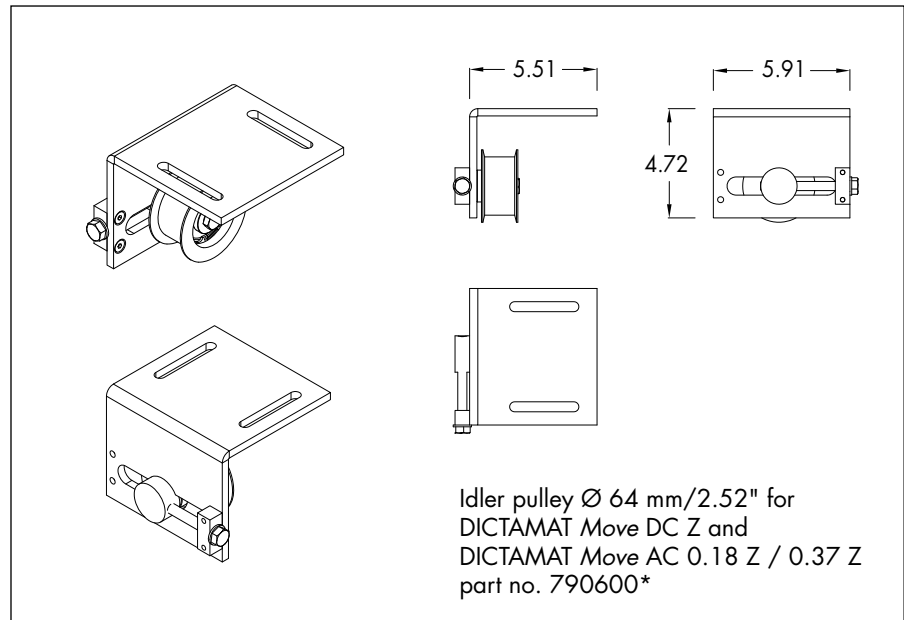

Dimensions Belt Fixing Device

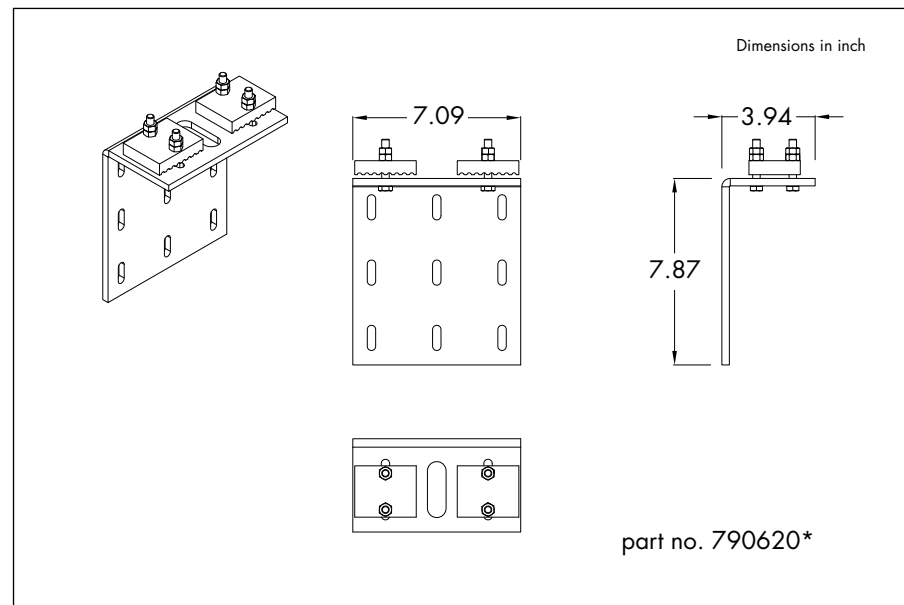

***NOTE**

The part numbers are given only in case spare parts are needed. Idler pulley and belt fixing device are included in the delivery of a door operator and have not to be ordered separately!

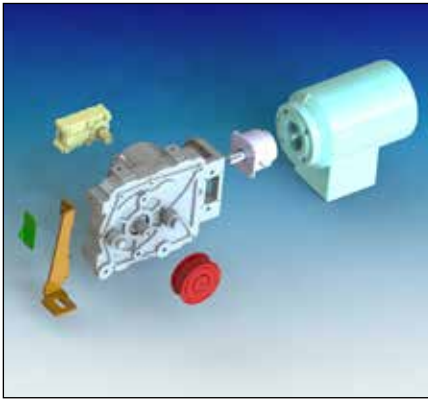

DICTAMAT Move Dimensions of Optional Accessories

For reasons of stability door operators for heavy doors are usually fixed to the wall. For this purpose special wall brackets are available which are designed especially to match the U-brackets of the operators and to withstand the high forces in case the brake springs into action.

The wall must be sturdy enough to absorb the pull and shear forces. Furthermore special dowels for dynamic loads have to be used.

Wall Bracket DC and AC 0.18 kW

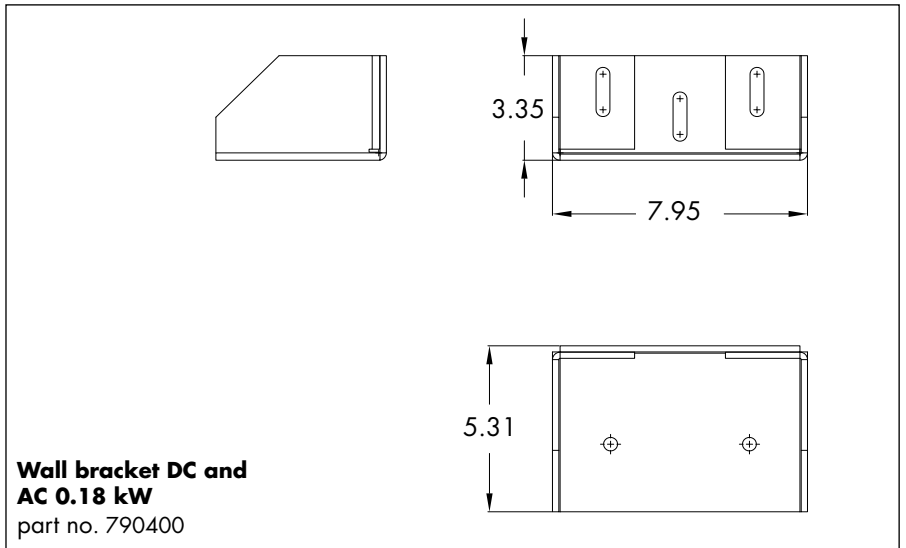
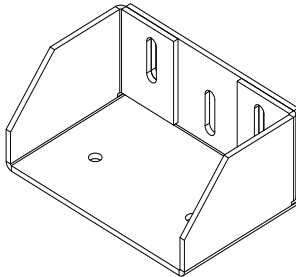

Range of application of wall bracket DC and AC 0.18 kW:

- DICTAMAT Move DC door operator and DICTAMAT Move AC 0.18 door operator
- Idler pulley with tensioning device for DICTAMAT Move DC and AC 0.18
- Idler pulley with tensioning device for DICTAMAT Move AC 0.37 Z
- Supporting roller for DICTAMAT Move Z

Wall Bracket 0.37 kW

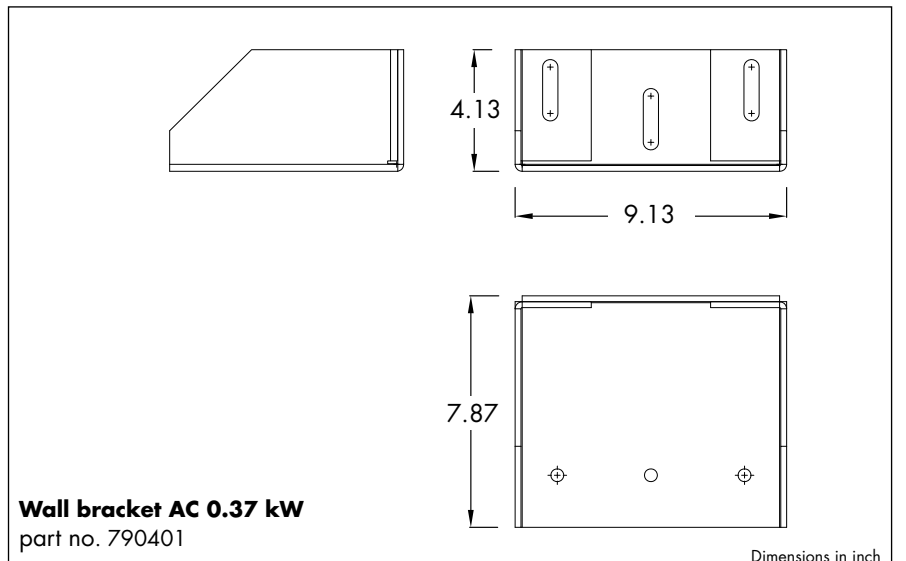
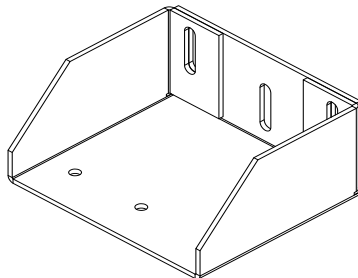

Range of application of wall bracket 0.37 kW:

- DICTAMAT Move AC 0.37 door operator

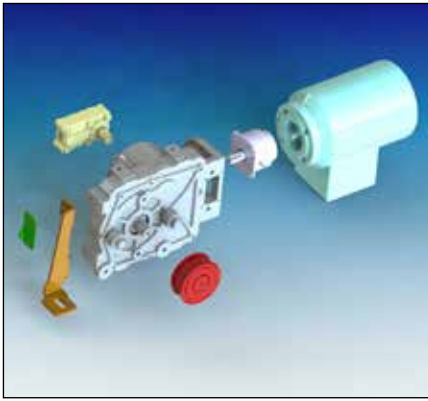

**DICTAMAT Move
Dimensions of Optional Accessories - cont.**

The supporting roller as well as the belt fixing device for the second door leaf are the same for all DICTAMAT Move Z door operators.

Supporting rollers prevent the sagging of the toothed belt. They have to be used whenever the toothed belt would run unsupported for more than 13 ft. The rollers are generally furnished together with an U-bracket. An additional wall bracket is available (see previous page).

In case of **double-leaf doors** an additional belt fixing device is required. To this device is always fixed the upper part of the belt.

**Supporting Roller for
0.79/1.18" Toothed Belt**

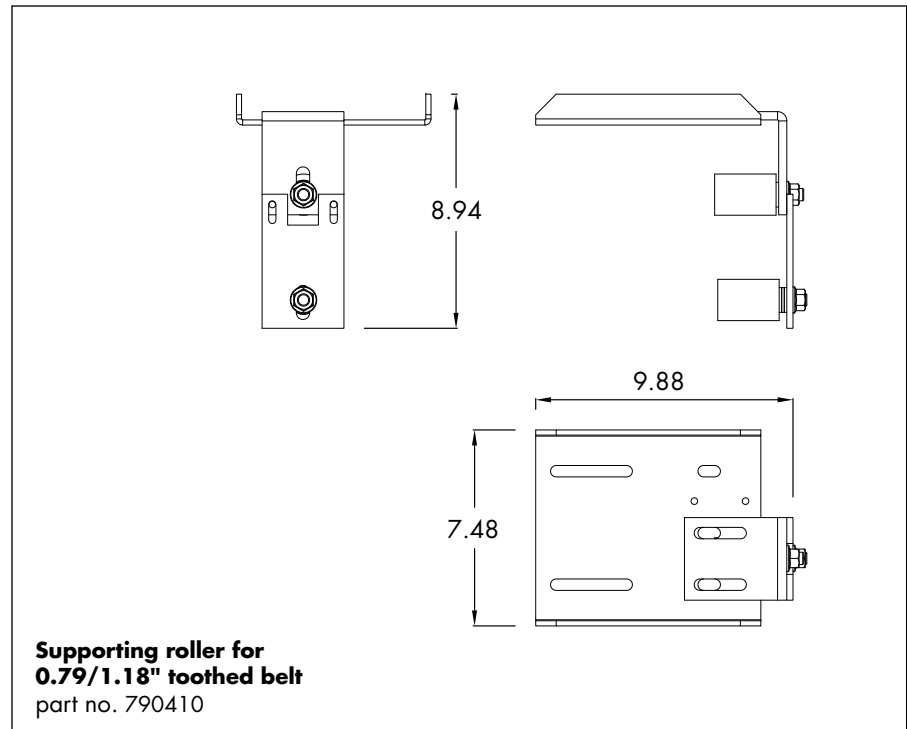
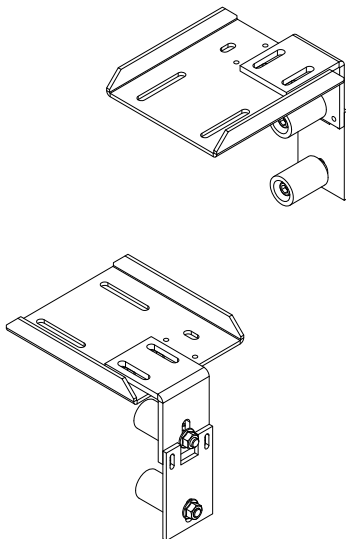

**Belt Fixing Device for
Second Leaf with Double-
Leaf Doors (0.79/1.18"
Toothed Belt)**

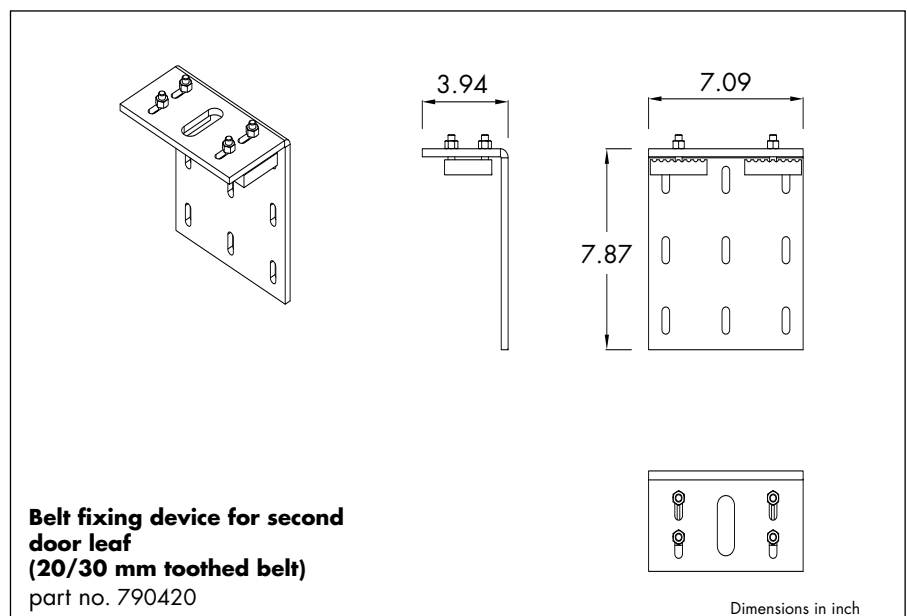
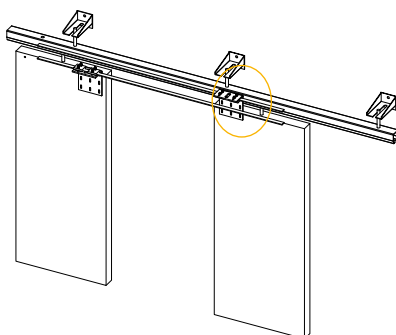

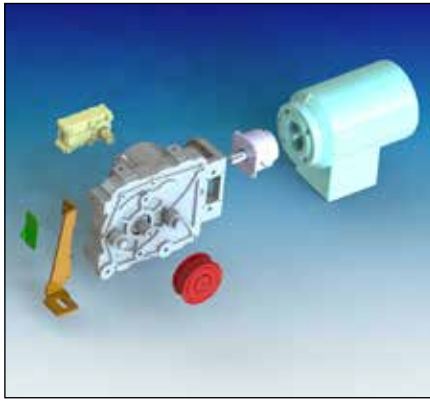

DICTAMAT Move Dimensions of Optional Accessories - cont.

With the DICTAMAT Move door operators, by default, the power is transmitted by toothed belt. Depending on the size, weight and speed of the door is used a toothed belt of 0.79" or 1.18" width.

With customized models the power can also be transmitted e.g. by chain. Usually then a chain 1/2 x 3/16" is used.

Toothed Belt

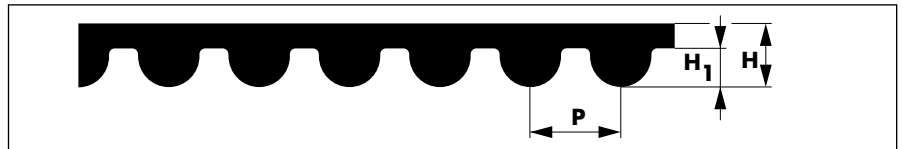

Type Toothed belt	HTD 8M
P	0.31"
H	0.22"
H₁	0.14"

Material	PU (Polyurethan)		
Tensile material	steel cord		
Operating temperature	-22° to 176 °F		
Resistant against	UV, ozone, oil und grease		
Tension load	- HTD 8M toothed belt, 0.79" wide	603 lbf	part no. 710490
	- HTD 8M toothed belt, 1.18" wide	906.75 lbf	part no. 710491



DICTAMAT MultiMove - Multi Control Control System

The control system of the DICTAMAT *MultiMove* drive system is composed of modules - same as the operators. The basic module is a logic unit with uniform hardware for all operators (including fire protection). This logic unit is upgraded by modules corresponding to the application, the used motor, the desired functions etc.

Always with the same operation and unchanging dimensions of the casing the control system offers the user an extremely wide range of functions. Usually there can be realized **later modifications** even **without having to replace the control system**.

Multi Control Control Systems

When developing the control system *Multi Control* of the DICTAMAT *MultiMove* drive system we payed highest attention to reduce the mounting and programming work on site as much as possible and to considerably facilitate meeting the demands of the Machinery Directive.

The **control systems** are, as far as possible, **adapted to the respective applications already in production**. Furthermore, the control system nearly automatically "learns" the **final positions, the required stopping distances etc. during the programmed teach-in run** on site. If at all, only some small adjustments will be needed.

The *Multi Control control system* meets the high safety demands of the EN 13241 part 1 and subordinated ones like the EN 12453. One of them being that the door stops after an extremely short distance when recognizing an obstacle. In case of a power cut when the door is moving the **short-term power supply of the electromagnetic brake** is backed up by supervised **capacitors**. As an additional safety feature all DICTAMAT *MultiMove* control systems are equipped with an **integrated load breaking** which functions as well with **DC** as with **AC** operators.

Summary of Performance

Motors that can be connected	230/400 VAC (three-phase) up to 0.37 kW or 24 VDC up to 240 W
Position control	encoder (accuracy of positioning about 0.04")
Motor control	integrated frequency converter for 230/400 VAC motors or DC controller
Password protection	for security relevant adjustments
Operation modes	dead man, impulsion, automatic operation can be chosen, emergency service with defect safety installation. Fire protection with mechanical closing or with emergency power supply
Inputs	10 inputs, configuration depending on control system
Outputs	10 outputs 24 V, configuration depending on controller
Standards	mainly EN 13241-1, EN 12453, EN 13849-1

Technical Data

Rated voltage	230 VAC, 50 - 60 Hz
Power consumption	max. 10 A
Output voltage secondary	24 VDC
Total load secondary	max. 1 A per output, total max. 2 A
Rating emergency power	24 V, 7 Ah
Output voltage motor	230/400 VAC (three-phase) or 24 VDC
Motor rating	max. 0.37 kW AC / 240 W DC
IP rating	IP 54
Dimensions	23.9 x 5.26 x 7.48 inch (w x h x d)
Recommended fuse protection	B16 A



Multi Control Control System - Dimensions, Structure

The DICTAMAT *Multi Control* control system has a modular structure. Depending on the door operator and the desired functions the corresponding modules are combined and programmed.

The casing of the control system is the same for all versions.

Dimensions Multi Control Control System

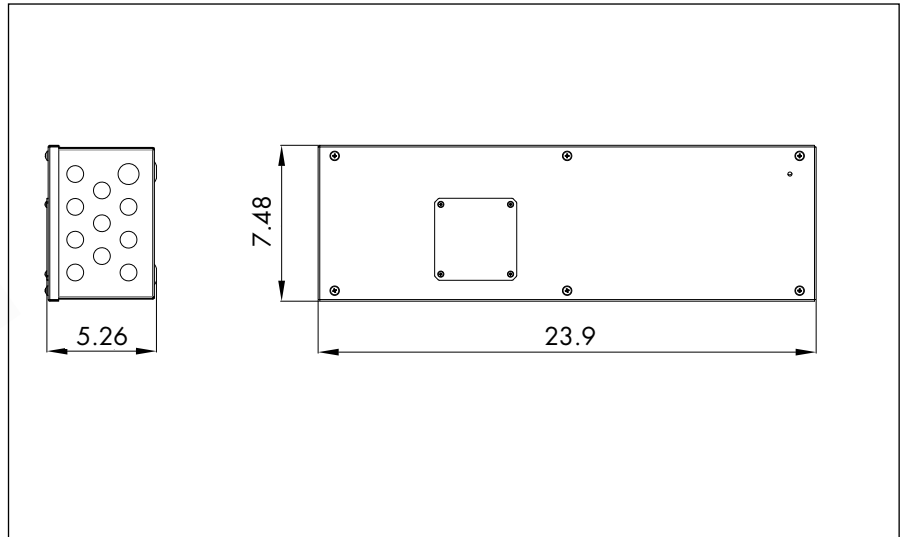
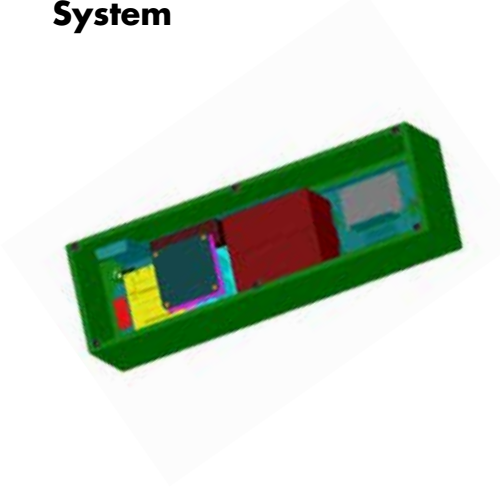

Structure Multi Control Control System



Casing	powder-coated steel
Display	display with programming and adjusting keys
Logic unit	basic module with uniform programming for all door operators
Connection board	predetermined configuration of clamps with ECONOMY and COMFORT versions, configuration according to customer's specification with CUSTOM version
Power element	DC or AC, depending on the connected door operator (with an AC version the frequency converter is included)
Fire protection module	version for motor-driven opening and mechanical closing
Emergency power module	battery pack with loading unit and surveillance of the state of charge



DICTAMAT Multi Control Control System - Functions

Basically there exist three different versions of the *Multi Control* control system, each with a different range of functions - see below.

However, it is possible to **upgrade the control functions**, also **subsequently** when the control system is already mounted! You can input the corresponding module simply by using a laptop.

This way the *Multi Control* control system offers the highest possible flexibility and can easily be adapted to changed requirements.

Features Multi Control

All versions of the *Multi Control* control system offer the following features:

- **Teach-in run:** "Intelligent", software assisted learning of the door parameters.
- **Dynamical run:** The teach-in run is followed by an automated dynamical run. Here the driving system determines during the complete run the running characteristics of the door. These values are the basis on which the control system calculates the necessary values for the acceleration and deceleration of the door taking into account its smooth/rough operation.
- **Intelligent recognition of obstacles:** Based on the values determined during the dynamical run, the control system is able to promptly detect any change of the performance of the door due to an obstacle. In this case the control system triggers an immediate Emergency-STOP followed by a reversion of the door movement.
- **Extensive diagnostic function:** Information retrieval and indication of all operating states and of errors/error indications by a double-spaced full text display.
- **USB interface:** Possibility to connect a computer for changing parameters of the control system on site.
- **EN ISO 13849-1:** *Multi Control* has been designed to use safety systems corresponding to the newest directives.

Functions of the Different Versions

Multi Control ECONOMY

- Dead-man operation
- Used inputs: Open, Close, Emergency-STOP
- Used outputs: none

Multi Control COMFORT

- Impulse operation, automatic closing
- Used inputs: Open, Stop, Close, Emergency-STOP, safety device in opening direction, safety device in closing direction, partial opening for people
- Used outputs: signal final Open position, signal final Closed position, motion warning with optional lead time, signal Emergency-STOP actuated, signal error

Multi Control COMFORT emergency power supply

Same as Multi Control Comfort, however, additionally used output: signal battery low

Multi Control CUSTOM

Completely customized programming and using of the inputs and outputs



DICTAMAT MultiMove Order Information

Below you will find an overview of the part numbers of the **bidirectional** door operators and control systems of the DICTAMAT MultiMove drive system.

In case you need a concrete offer, please contact our technical service. We gladly will provide advice and elaborate a free of charge, detailed offer which takes into consideration your specific requirements and all relevant safety aspects.

Order Information DICTAMAT MultiMove - bidirectional

Version of the door operator		Appropriate Multi Control control system			
Name	Part no.	ECONOMY	ECONOMY Emergency power	COMFORT	COMFORT Emergency power
DICTAMAT Move DC 90 Z V+	740000	740100	740101	740105	740106
DICTAMAT Move DC 90 Z P+	740005	740100	740101	740105	740106
DICTAMAT Move DC 200 Z P+	740010	740100	740101	740105	740106
DICTAMAT Move AC 0,18 Z V+	740050	740150	—	740155	—
DICTAMAT Move AC 0,18 Z P+	740055	740150	—	740155	—
DICTAMAT Move AC 0,37 Z P+	740060	740150	—	740155	—

For all DICTAMAT Move door operators also the Multi Control Custom control system is available. Its configuration is customized and adapted to your requirements.

General information on the DICTAMAT Move operators: beginning on page 04.015.00
Information on the Multi Control control systems: beginning on page 04.022.00

Standard Components Included DICTAMAT Move Z - bidirectional

- Motor with gearbox and mounting U-bracket, 6.56 ft of connection cable to the control system, driving wheel for 0.79 or 1.18" toothed belt, protective guard
- Idler pulley for toothed belt with integrated tensioning device and U-bracket
- Belt fixing device with clamp plates for toothed belt

Order Information DICTAMAT MultiMove - Accessories

Wall bracket for DICTAMAT Move DC and AC 0.18 KW and for idler pulleys and supporting roller	part no. 790400
Wall bracket for DICTAMAT Move AC 0.37 KW	part no. 790401
Supporting roller for 0.79" and 1.18" toothed belt	part no. 790410
Belt fixing device for toothed belt for second door leaf	part no. 790420
Toothed belt HTD 8M, 0.79" wide (per meter/approx. 3.28 ft)	part no. 710490
Toothed belt HTD 8M, 1.18" wide (per meter/approx. 3.28 ft)	part no. 710491

For information on safety and operating equipment see separate pages.

AC-21 Sliding Door Operators

DICTAMAT 900-21

The DICTATOR **DICTAMAT 900-21** door operator series in combination with the SQUARE 940-2 control system complies with the **requirements of the EN 12453 for the "Safety in use of power operated doors"**.

All door operators are equipped with a **mechanical brake** that assures the stop of the door within the required distance even without current. An integrated thermal cutout protects the operator from too high loads.

The position control is done either with **separate limit switches** or an **encoder**, integrated in the motor, that permits a very precise positioning.

Due to the mechanical brake the motor is blocked without current. If the door has to be moved by hand in case of a power failure an additional **mechanical cranking device** can be supplied.

DICTATOR will gladly offer you a solution taking into account the requirements of your individual application. Please ask for a detailed offer and if necessary, CAD-drawings.



Selection Criteria

- For doors up to 32.81 ft (standard)
- Pulling forces from 83.25 to 495 lbf
- For doors up to max. 8800 lbs
- For up to 300 cycles per day (depending on the weight of the door and the speed)
- Position control: integrated encoder or separate limit switches
- Motor blocked without current
- Control system: SQUARE 940-2
- According to EN 12453



Summary

The new AC-21 series is a consequent application of the modular system already used with the DC-21 series. The AC-21 series offers the possibility of powered operation also of extremely large and/or heavy doors according to the requirements of the EN 12453. The modular system permits individual, customized solutions for every door. All door operators are based on similar modules and are operated with the same control system.

The values in the table below are just for orientation and a preselection. They may differ considerably depending on the type and design of the door, additional standards and legal requirements valid for the respective site. Please ask for our technical support and our customized offer.

Technical Data

Type / Motor Rating	0.18 kW	0.18 kW	0.37 kW	0.55 kW
Force of the motor	83.25 lbf	141.75 lbf	270 lbf	495 lbf
Opening and closing speed	separately adjustable			
max. inch/sec.	15.75	7.87	7.87	5.91
Voltage	230/400 VAC			
Nominal current pf the control system	8 A	8 A	8 A	8 A
Driving torque (at the axle of the operator)	10.33 lbf ft	17.7 lbf ft	44.9 lbf ft	110.63 lbf ft
Braking moment (mechanical brake)	2.95 lbf ft	2.95 lbf ft	3.69 lbf ft	7.38 lbf ft
Duty cycle	40 % ED			
IP rating	IP 55			
Weight (without accessories)	22 lbs	22 lbs	46.2 lbs	88 lbs
Doors up to*	1320 lbs*	2200 lbs*	3300 lbs*	8800 lbs*
Travel	19.69 ft	19.69 ft	32.81 ft	32.81 ft

* The given weights are just reference values. The determining point is how easily the door moves.

Options

- Position control

The standard operator is designed for separate limit switches. The control system however identifies an additional Open position (partial opening) without an extra limit switch. The control system calculates this position - if adjusted once - from the final positions and the memorized travel.

The AC-21 door operators are also furnished with an integrated encoder.

- Mechanical brake

The standard AC-21 operators are equipped with a mechanical brake making sure that even in case of a power failure the door is stopped within the required distances. In case of doors to which the EN 12453 standard does not apply, the door operators can also be furnished without the mechanical brake.

- Mechanical cranking device (not possible with the 0.55 kW operators)

All door operators with integrated mechanical brake impede moving the door without current. If the doors have to be moved manually in case of a power failure, the following options are available: additional mechanical cranking device or electromagnetic clutch.

- Accessories

Due to the extremely high forces that occur upon the actuation of the mechanical brake extremely sturdy fixing brackets are required. As the door operator therefore normally cannot be fixed to the rail, we supply special brackets for fixing the door operator to the wall.



Components

The AC-21 door operators transmit the power to the door with the help of a revolving toothed belt. They are normally fixed to the wall, as the rails cannot take up the forces resulting from the action of the mechanical brake.

The following picture shows the components of a AC-21 door operator system for sliding doors.

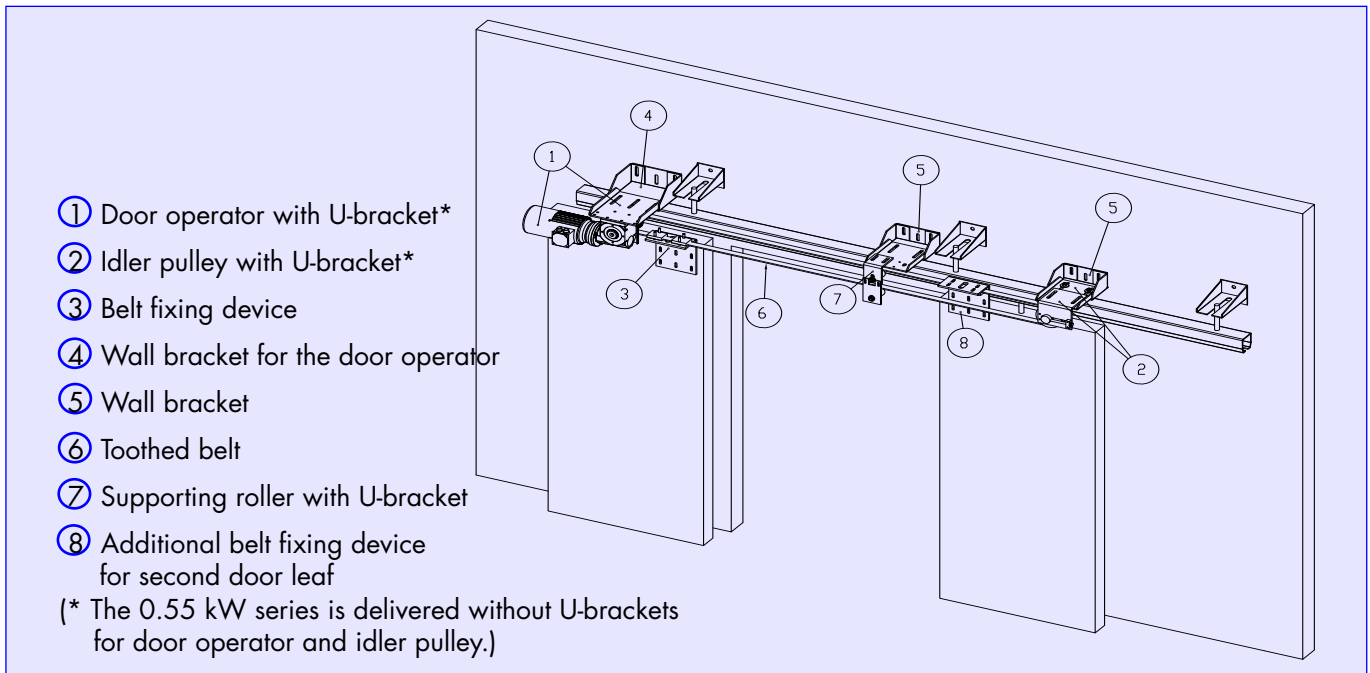

Components Included DICTAMAT 900-21

- Door operator: worm gear transmission with a 230/400 VAC three-phase motor and integrated mechanical brake, integrated thermal cutout, 6.56 ft connection cable to the control system, driving wheel for toothed belt
- U-bracket for the door operator*
- Idler pulley for toothed belt with integrated tensioning device and U-bracket*
- Belt fixing device for the door

Additional Components

- Integrated encoder
- Mechanical cranking device
- Electromagnetic clutch

Separate Accessories

- Toothed belt (type depends on the motor)
- Wall bracket for the door operator
- Wall bracket for the idler pulley
- Supporting roller with U-bracket for the toothed belt
- Wall bracket for the supporting roller
- Additional belt fixing device for sliding doors with two leaves



DICTAMAT 900-21, 0.18 kW

The standard components of the DICTAMAT 900-21, 0.18 kW are besides the door operator with U-bracket the idler pulley for toothed belt with integrated tensioning device as well as the belt fixing device. The 0.18 kW door operator uses the HTD 8 toothed belt. The width (either 0.79 or 1.18") depends on the weight of the door and the required speed.

The 0.18 kW door operator needs an especially designed idler pulley. The belt fixing device is used both for the 0.18 and 0.37 kW door operator.

Wall brackets for the door operator and the idler pulley are to be found on page 04.033.00.

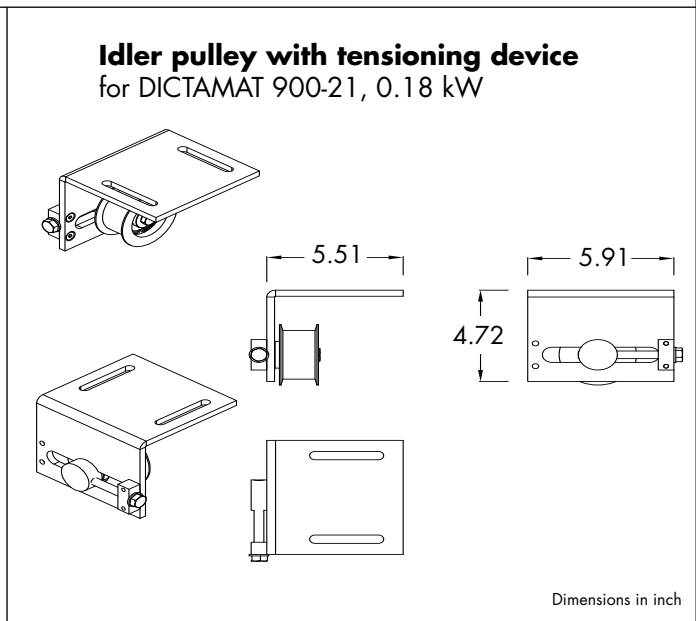
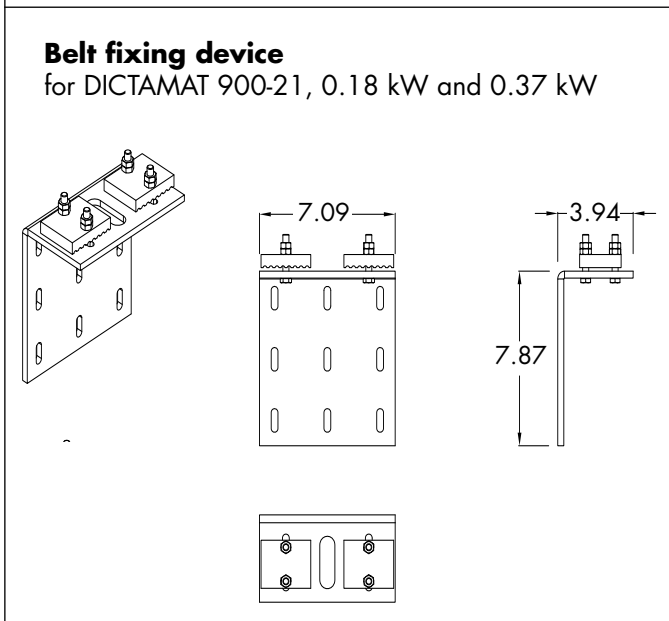
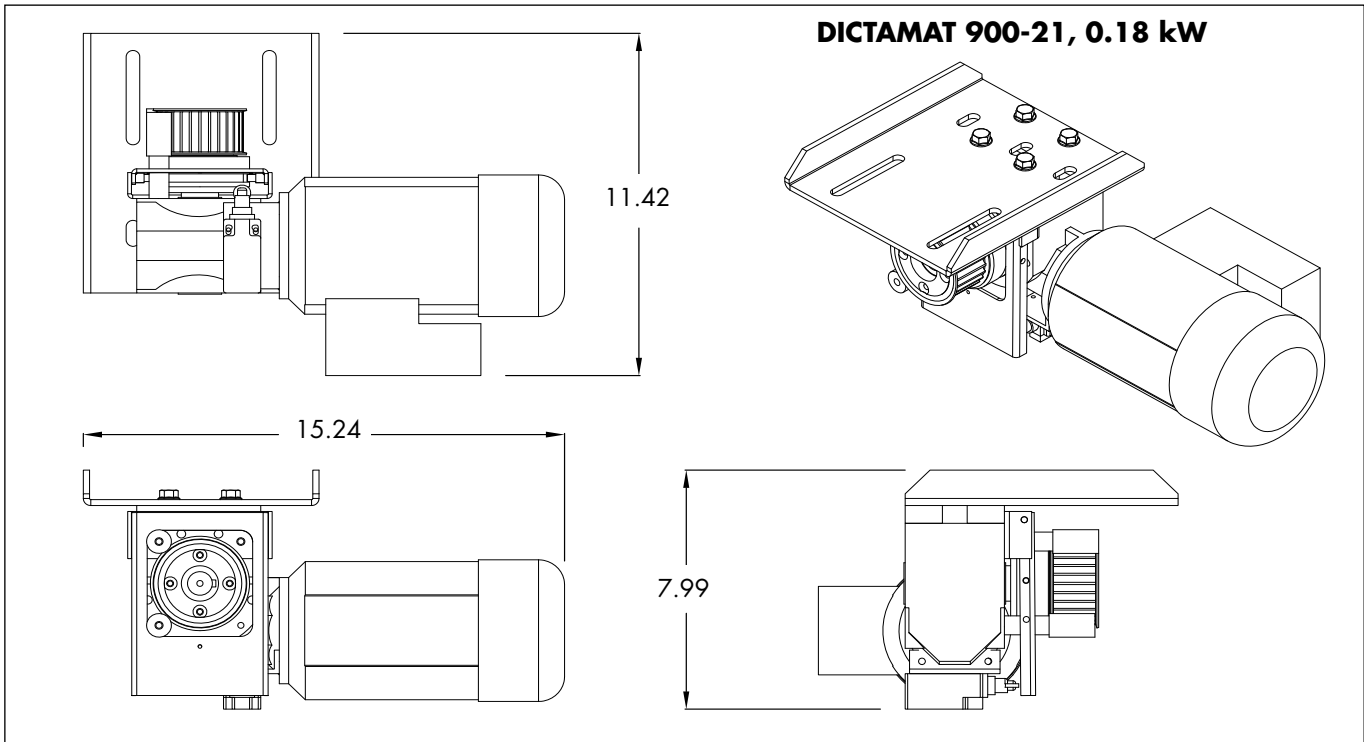

Dimensions in inch



DICTAMAT 900-21, 0.37 kW

The standard components of the DICTAMAT 900-21, 0.37 kW are besides the door operator with U-bracket the idler pulley for toothed belt with integrated tensioning device and U-bracket as well as the belt fixing device.

The 0.37 kW door operator uses the 1.18" wide HTD 8 toothed belt.

The 0.37 kW door operator needs an especially for this type designed idler pulley. The belt fixing device is used both for the 0.18 and 0.37 kW door operator.

Wall brackets for the door operator and the idler pulley are to be found on page 04.033.00.

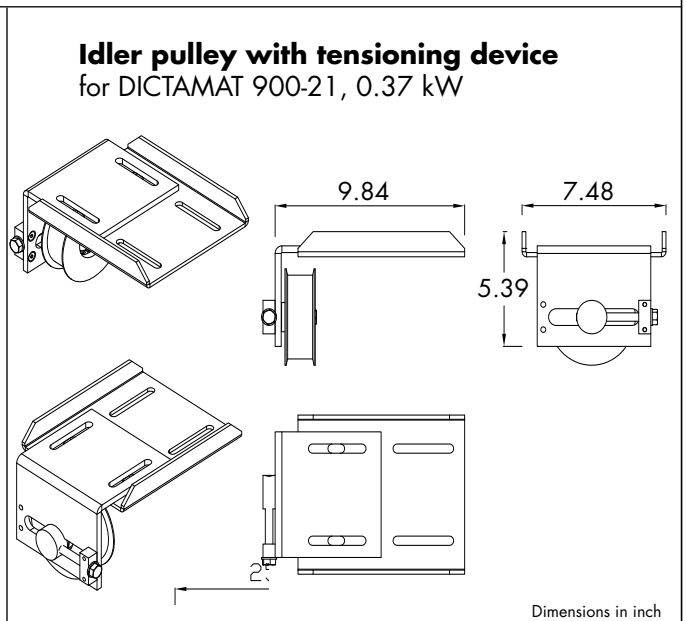
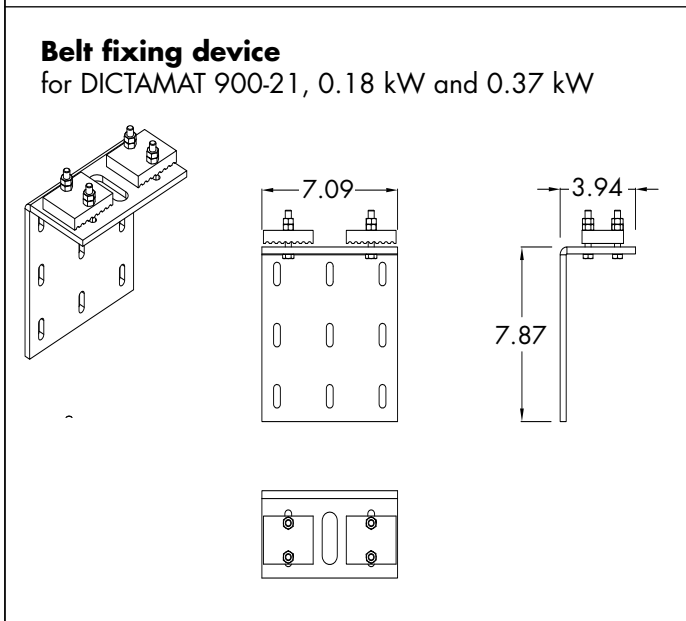
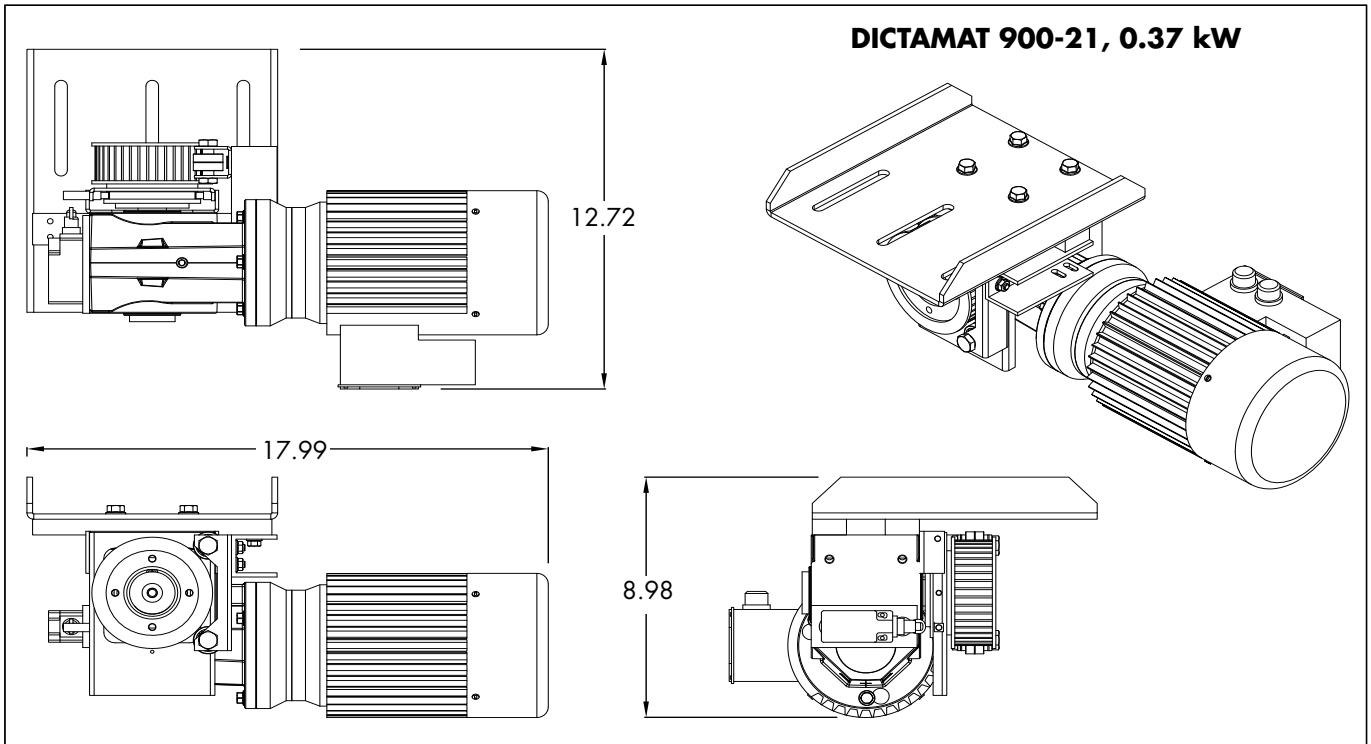

Dimensions in inch



DICTAMAT 900-21, 0.55 kW

The standard components of the DICTAMAT 900-21, 0.55 kW are besides the door operator the idler pulley for toothed belt with integrated tensioning device as well as the belt fixing device. Due to the extremely high forces acting in case of the mechanical Emergency-Stop fixing brackets have to be designed individually for each application. The 0.55 kW door operator uses a 2.17" wide toothed belt.

DICTAMAT 900-21, 0.55 kW

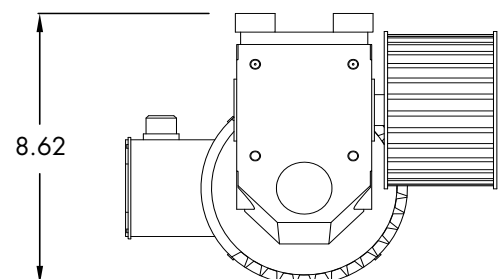
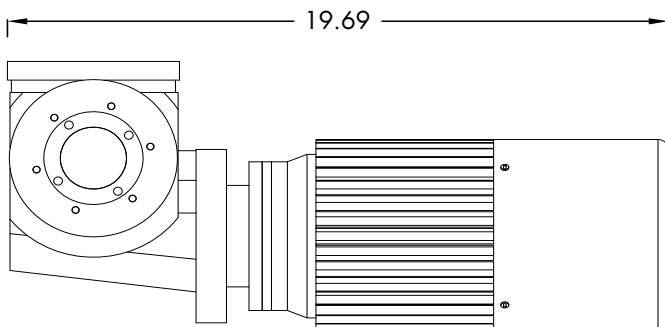
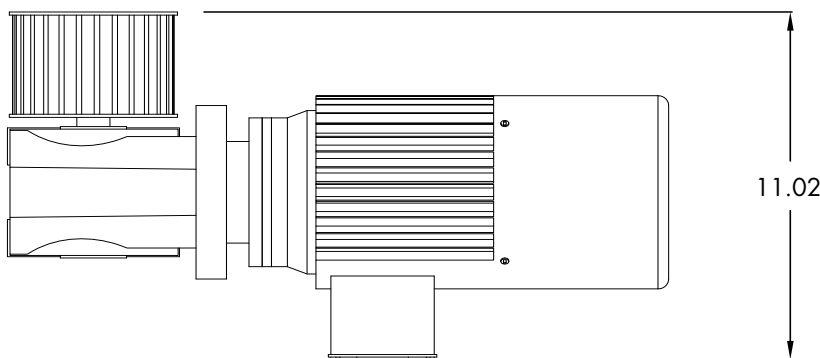
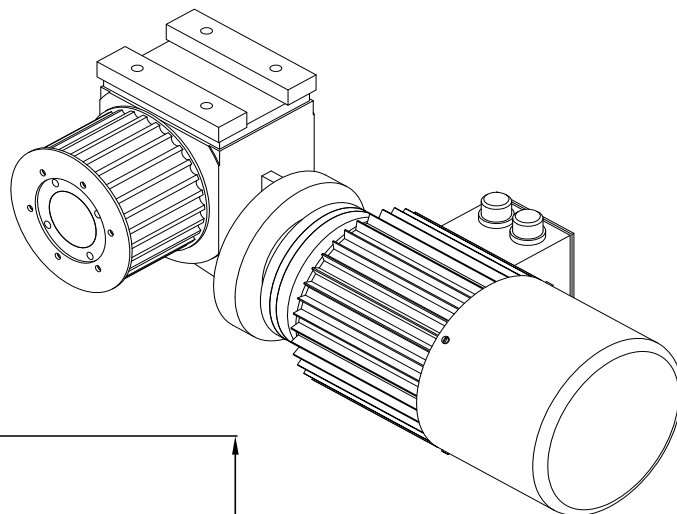

Dimensions in inch



Accessories

In order to assure the necessary stability the DICTAMAT 900-21 door operators are normally fixed to the wall. There are special wall brackets available that are designed especially for the U-brackets delivered with the door drives and that withstand the high forces in case of an Emergency-Stop.

The wall must be sturdy enough to absorb the pull and shear forces. Furthermore special dowels for dynamic loads have to be used.

Wall Bracket 0.18 kW

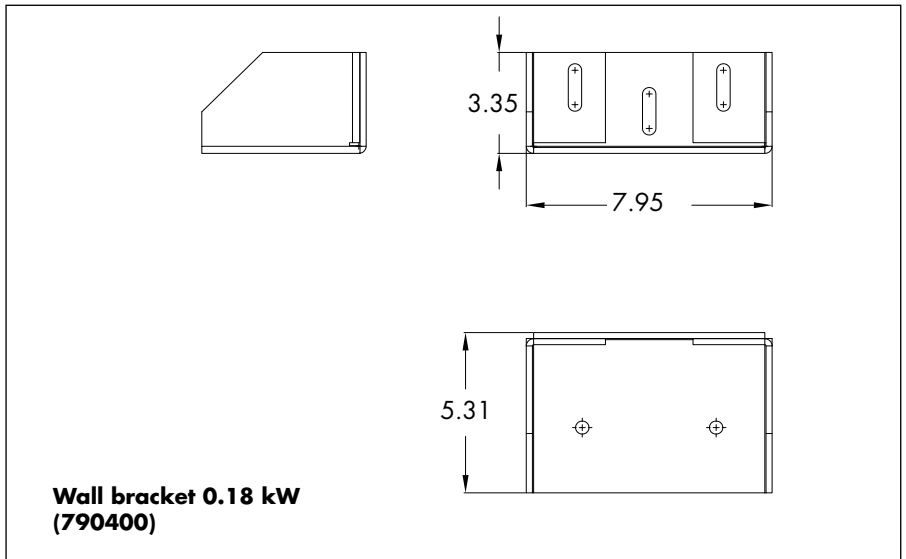
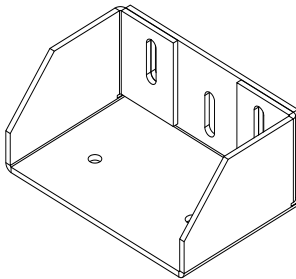

Use of the wall bracket 0.18 kW:

- DICTAMAT 900-21, 0.18 kW door operator
- Idler pulley with tensioning device for DICTAMAT 900-21 0.18 kW
- Idler pulley with tensioning device for DICTAMAT 900-21 0.37 kW
- Supporting roller for DICTAMAT 900-21 0.18 and 0.37 kW

Wall Bracket 0.37 kW

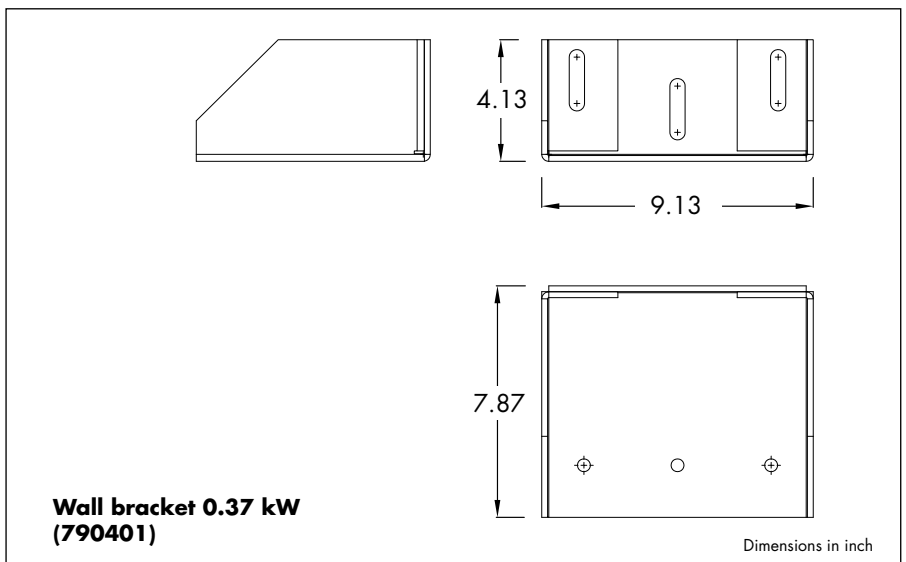
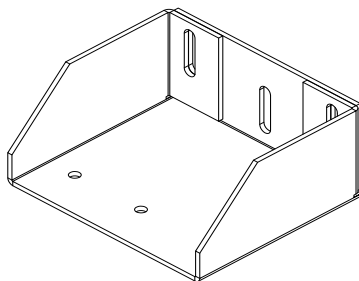

Use of the wall bracket 0.37 kW:

- DICTAMAT 900-21, 0.37 kW door operator



Accessories - continued

Some of the accessories can be used both for the 0.18 kW and 0.37 kW series. Among those are the supporting roller for the thoothed belt and the additional belt fixing device for doors with two leaves.

The supporting rollers prevent the sagging of the belt. They have to be used whenever the toothed belt would run unsupported for more than 13.12 feet. The rollers are generally furnished together with an U-bracket. An additional wall bracket is available (see preceding page).

In case of doors with two leaves an additional belt fixing device is required. It is always the upper part of the belt that is fixed to this device.

Supporting Roller for 0.79/1.18" Toothed Belt

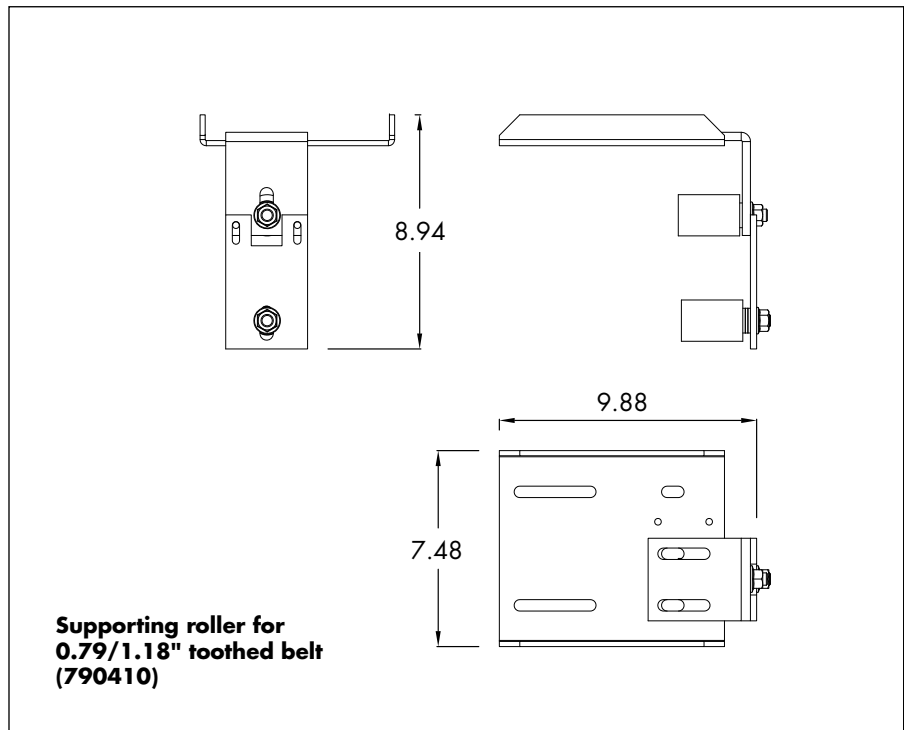
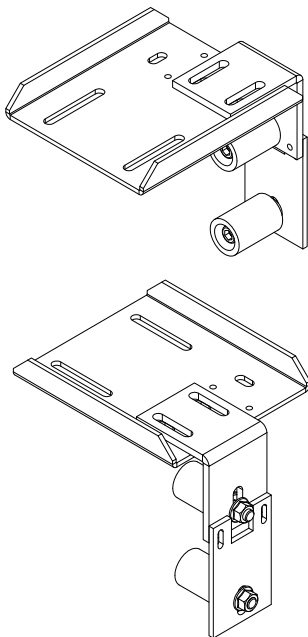

Belt Fixing Device for Doors with Two Leaves (0.79/1.18" Toothed Belt)

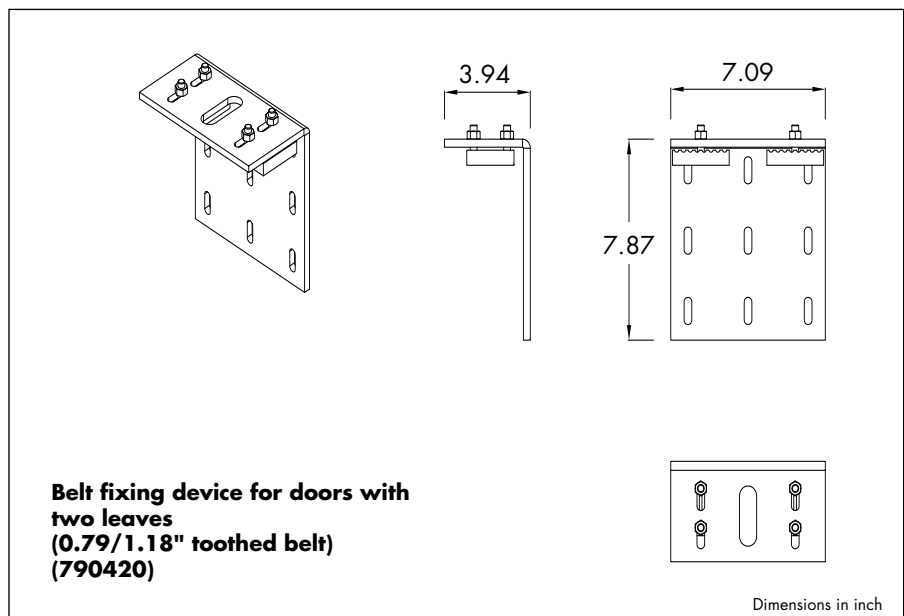
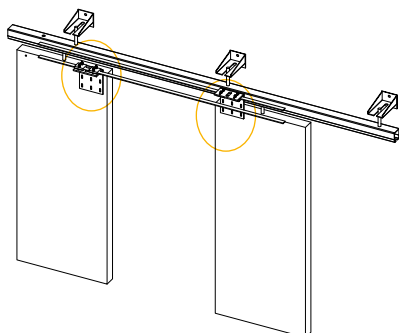

Dimensions in inch



Accessories - continued

The power transmission of the AC-21 door operators is done with a toothed belt. There are different types, depending on the size of the door and the forces. The EN 12453 standard requirements result in a rather strong toothed belt for larger doors.

Toothed Belt

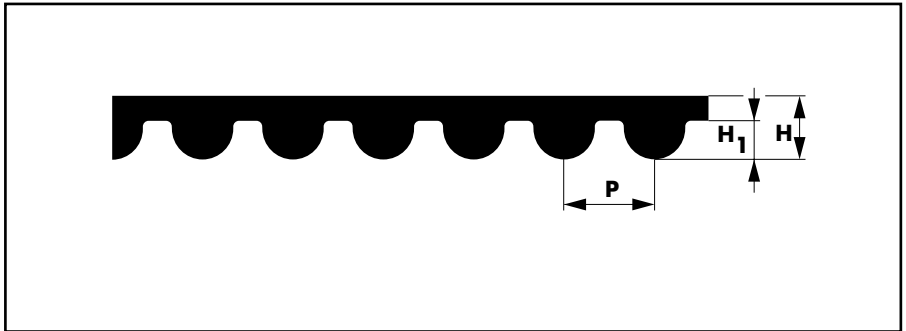

Technical Data

Type	HTD 8M	HTD 14M
P	0.31"	0.55"
H	0.22"	0.42"
H₁	0.13"	0.24"

Material	PU (polyurethane)	
Tensile material	steel cord	
Operating temperature	-22° to +176 °F	
Resistant against	UV, ozone, oil and grease	
Tension load:	- HTD 8M toothed belt, 0.79" wide	603 lbf
	- HTD 8M toothed belt, 1.18" wide	906.75 lbf
	- HTD 14M toothed belt, 2.17" wide	2459.25 lbf



Order Information

Below are listed the part numbers of the most common door operators. There is a much larger range of door operators available, e.g. with mechanical cranking device etc. Please contact us and ask for an offer for your application.

The components included in the delivery are listed on page 04.029.00. The meaning of the different letters and numbers is explained below.

Information on the SQUARE 940-2 control system and further components of a powered door installation as push buttons, safety equipment and limit switches are to be found later on in this chapter.

Order Information Door Operators

DICTAMAT 900-21 ZEB	0.18 - 0.4 (15.75"/s)	part no. 790000
DICTAMAT 900-21 ZLB	0.18 - 0.4 (15.75"/s)	part no. 790050
DICTAMAT 900-21 ZEB	0.18 - 0.2 (7.87"/s)	part no. 790100
DICTAMAT 900-21 ZLB	0.18 - 0.2 (7.87"/s)	part no. 790150
DICTAMAT 900-21 ZEB	0.37 - 0.2 (7.87"/s)	part no. 790200
DICTAMAT 900-21 ZLB	0.37 - 0.2 (7.87"/s)	part no. 790250
DICTAMAT 900-21 ZEB	0.55 - 0.15 (5.91"/s)	part no. 790300
DICTAMAT 900-21 ZLB	0.55 - 0.15 (5.91"/s)	part no. 790350

Order Information Accessories

Wall bracket 0.18 kW	part no. 790400
Wall bracket 0.37 kW	part no. 790401
Supporting roller for 0.79/1.18" toothed belt	part no. 790410
Belt fixing device for doors with 2 leaves (0.79/1.18" toothed belt)	no. 790420
HTD 8M toothed belt, 0.79" wide	part no. 710490
HTD 8M toothed belt, 1.18" wide	part no. 710491
HTD 14M toothed belt, 2.17" wide	part no. 710485

Order Information Control System

SQUARE 940-2 Control system	part no. 706094-2
-----------------------------	-------------------

Information about the control system can be found beginning on page 04.037.00.

Legend:

- Z Power transmission by toothed belt
- E Position control with separate limit switches
- L Position control with integrated encoder
- B Mechanical brake
- 0.18 - 0.4 Motor 0.18 kW, speed 0.4 m/s (inch/s)

SQUARE 940-2 Control System with Frequency Converter According to EN 12453

The SQUARE 940-2 control system has been developed for the DICTAMAT AC-21 door operators (sliding door operator DICTAMAT 900-21 and hinged door operator DICTAMAT 310-21). It **meets** the **demands of the EN 12453** concerning the safety of powered doors.

Its **main advantages** are:

- **Autocontrol**, i.e. it shuts itself down automatically upon detecting an error that might lead to a dangerous situation.
- Direct connection of **safety equipment according to the EN 13849-1** without additional evaluation device.
- **Different "Stops"** of the door **adjustable**. This protects door and door operator during normal operation from unnecessary wear and tear due to an abrupt Stop. In case of danger the maximum stopping distance according to the EN 12453 is observed.
- Connection possibility for a mechanical braking device.
- The SQUARE 940-2 allows for a position control by an encoder and thus a very exact positioning.
- Graphic display on the casing lid with status and error indication.
- The membrane keys on the lid of the casing serve for operating the door.



Summary

Motors to be connected	three phase 230/400 VAC, max. 0.75 kW
Main features	position control: encoder or separate limit switches
	integrated frequency converter
	password protected access to adjustment facility
	deadman, impulse or automatic operation
	emergency service in case of faulty safety equipment
	5 adjustable relay contacts
	Meets the safety demands of the EN 12453.





Dimensions / Installation

The casing of the SQUARE control systems has been designed with **as small as possible outer dimensions**, in order to fit also into limited space. The **interior** of the casing however offers **sufficient space** to house - if necessary - additional devices or batteries. The carrier board is provided with threaded holes for standard top hat rails. This **saves** the expenses for additional casings, their installation and connection.

Dimensions of the Casing

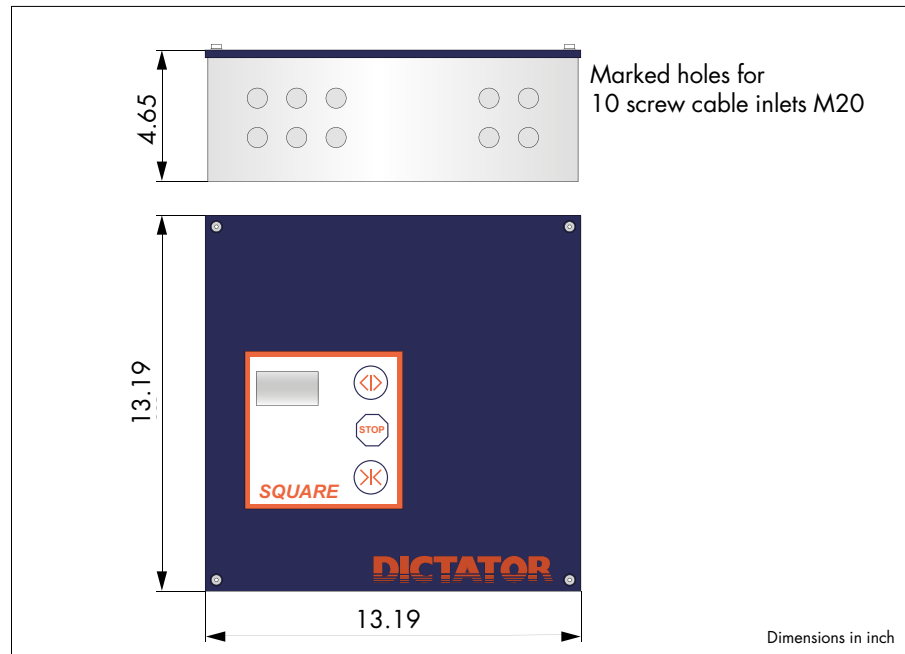

Installation / Electrical Connection of Door Operators

The installation of the control system is very easy, as the **electronics** are fixed **on a board that can be removed** completely from the casing. The lid of the casing can also be taken off, as the flat cable connection to the display in the lid just has to be unplugged. The now very light casing can be fixed to the wall, without the danger of damaging the electronics by chance with e.g. a screw driver.

The control system should be placed not farther than 98.43 ft from the door operator.

Door operator, operating elements and safety equipments are connected to the **removable binders**. The blocks of binders are coded and therefore cannot be plugged into a wrong position.

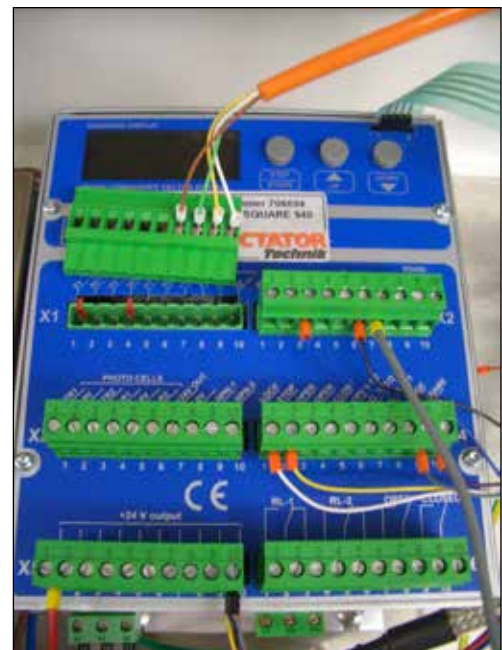



Functions, Programming and Adjusting

The SQUARE 940-2 control system permits to adjust the DICTATOR DICTAMAT door drive exactly to each door. This is a vital condition for the safety at powered doors.

The increased demands concerning the safety of the "machine door" due to the EN 12453 standard require a control and putting into operation by a trained and authorized technician. Therefore all safety relevant parameters are only accessible through a password. The below mentioned functions and parameters only give a general idea as the SQUARE 940-2 offers a much larger range of adjustments/functions.

Programming and Adjusting

Operating Options / Safety Features

All adjustments are done with the three adjustment keys on the control module.

- *Dead Man or Impulse Function* for the keys OPEN and CLOSE (can be chosen separately for both directions, e.g. impulse OPEN, dead man CLOSE)
- *Automatic Closing*: As soon as the position OPEN has been reached the door closes automatically after a preset time (adjustable between 1 - 999 seconds)
- *Alternating Impulse OPEN/CLOSE, also in combination with automatic closing*
- *Partial Opening*: The door opens only partially after pressing a separate push button (additional Open position for persons) (separately adjustable hold-open-time for this position)
- *STOP (Normal Stop when opening, Fast Stop when closing)*.
- *EMERGENCY STOP*: This works the same way as the safety equipment on the closing edge. Stopping distance according to EN 12453.
- *Safety Equipment (SHE)*: Different safety equipment can be connected to meet the EN 12453. The function of the safety equipment is cancelled in the final positions. After the safety equipment has been activated a new operating command is necessary to get the door moving again.

Securing the closing edge (direction CLOSE): When this SHE is activated, the door stops within the required distance and then reverses until it is again completely open. This SHE is in function only during closing.

Securing the opening edge (separate connection): When activated, the door reverses until it is again completely closed. SHE in function only during opening.

Additional safety type D, e.g. by a light barrier in closing direction (see table on page 04.007.00): Door stops with a Fast Stop (see below).

If the safety equipment should fail, an emergency service for the door can be adjusted (dead man operation). The door moves at creep speed only. As long as the emergency service has not been adjusted, the door can no longer be operated by motor.

Motor Parameters

In order to achieve an **optimum adjustment of the door drive to the door** different motor parameters can be adjusted. Amongst them are e.g.:

- *Motor Rating* (adaption to the connected motor)
- *OPENING Speed / CLOSING Speed* (separately adjustable)
- *Creep Speed* before reaching the positions OPEN and CLOSED (speed is reduced before reaching the final position, so that no separate final dampers are required, separately adjustable)
- *Acceleration and Deceleration Ramps*: Depending on the door weight and its easy movement
- *Fast Stop*: Adjustment of the Stop in closing and opening direction (separately adjustable)
- *EMERGENCY STOP*: Adjustment of the STOP characteristics upon activation of the safety equipment or by the Emergency Stop push button



Functions (cont.), Technical Data, Order Information

The SQUARE 940-2 control system permits a great deal of different operating functions. When choosing the operating mode the required safety equipment has to be provided. See also the summary on the requirements of the EN 12453 on page 04.007.00. A change to a "more dangerous" operating mode (e.g. from dead man to impulse operation) is only permitted when providing the required safety equipment.

The control system offers a high operating standard due to additional adjustment and connection possibilities.

Position Control

The SQUARE 940-2 control system is designed for a position control via encoder, integrated in the door operator. This permits a very precise positioning of the door (depending on the travel and the power transmission: max. 0.08"). However it is also possible to use separate limit switches (4 pcs. required).

Relay Contacts

The SQUARE 940-2 disposes of 5 relay contacts for controlling signalling and warning devices. There exists a large variety of adjusting possibilities. This permits e.g. the connection of signals, warning sirens, the connection to a building surveying central, a floor conveyor system etc.

Diagnostics

The display on the lid of the casing indicates error codes or different diagnostic codes for the input and output terminals. This helps also to locate a problem, even by telephone.

Application Range SQUARE 940-2

The SQUARE 940-2 control system with integrated frequency converter is designed for **door drives for sliding doors** (beginning on page 04.027.00) **and for hinged doors** (beginning on page 04.041.00) with a **three phase current motor**. It can control motors up to 0.75 kW.

AC-21 series	DICTAMAT 900-21
	DICTAMAT 310-21

Technical Data

Voltage	230 VAC, 50 - 60 Hz
Power consumption	8 A
Output voltage (secondary)	24 VDC
Power supply (secondary)	max. 500 mA
Output voltage motor	230/400 VAC (three phase)
Motor rating	max. 0.75 kW
Dimensions	H x W x D = 13.19 x 13.19 x 4.65"
IP rating	IP 54
Recommended fuse protection	16 A
Operating temperature	14 °F to 104 °F

Components Included

Control system in casing IP 54 with membrane keys and display on the casing

Order Information

SQUARE 940-2 control system for the AC-21 door operators part no. 706094-2

Hinged Door Operators AC-21 Dictamat 310-21

The Dictamat AC-21 hinged door operators fulfil in combination with the SQUARE 940-2 control system (see page 04.037.00 and the following) the **demands of the EN 12453 for the "Safety in use of power operated doors"**.

The Dictamat 310-21 has been designed for large and/or heavy hinged doors. These door operators are equipped with a **mechanical brake** that assures the stop of the door within the required distance even without current. An integrated thermal cutout protects the operators from too high loads.

The position control is done with an **encoder**, integrated in the motor, that permits a very precise positioning.

Due to the mechanical brake the motor is blocked without current. If the door has to be moved by hand in case of a power failure, the operators are provided with an electromagnetic clutch.

Dictator will gladly offer you a solution taking into account the requirements of your individual application.

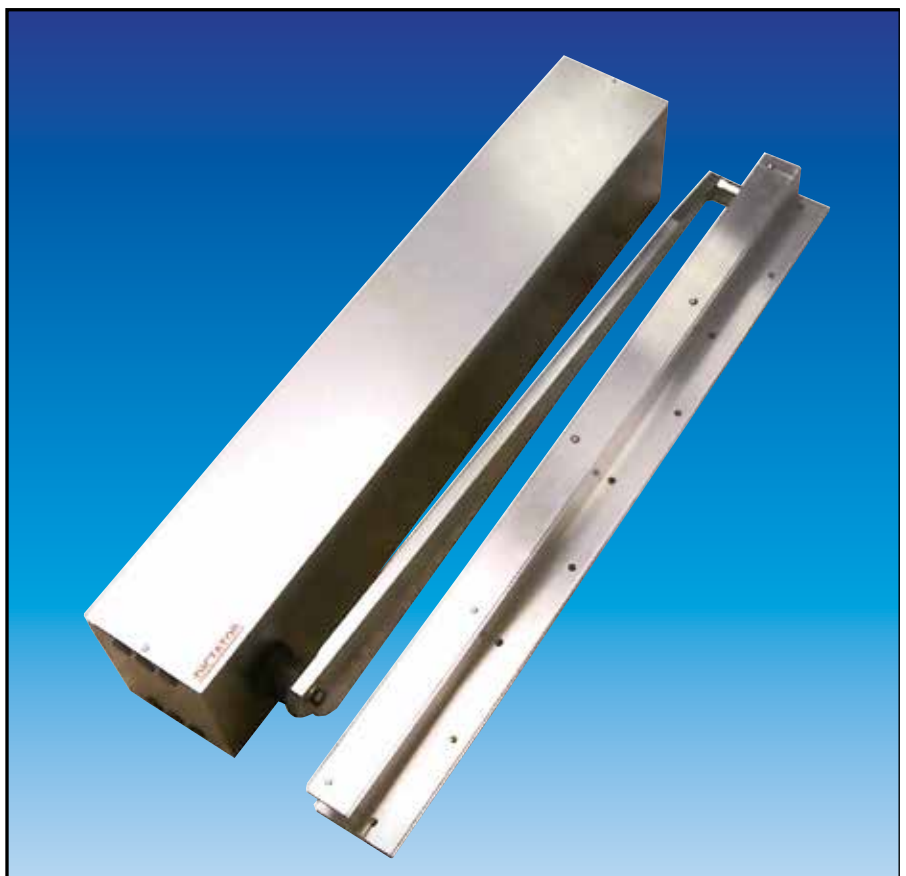

Selection Criteria

- For hinged doors up to 8.2 ft width
- Force of the door operator max. 516.29 lbf ft
- For doors up to max. 1320 lbs
- For up to 300 cycles per day (depending on the weight and speed of the door)
- Position control: integrated encoder or separate limit switches (on demand)
- Motor blocked without current
- Control system: SQUARE 940-2
- Meets the demands of the EN 12453

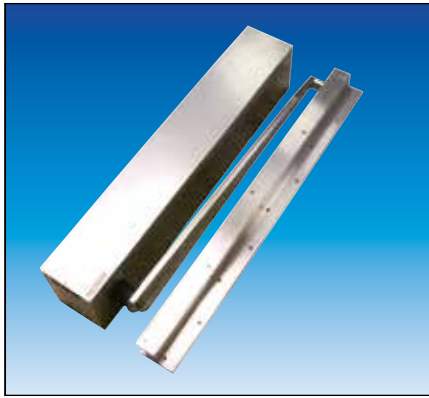

Summary

The AC-21 series offers the possibility of powered operation of extremely large and/or heavy doors according to the demands of the EN 12453. The modular system permits individual, customized solutions for each door. All door operators are based on similar modules and are operated by the same control system.

The values in the table below are just for orientation and a preselection. They may differ depending on the type and design of the door, additional standards and legal demands valid for the respective site.

For hinged doors there are basically two different door operators. But if necessary, further types are possible. Please ask for our technical support and a customized offer.

Technical Data

Type	Standard	XXL
Motor rating	0.18 kW	0.18 kW
Force of the motor max.	147.5 lbf ft	516.3 lbf ft
Opening and closing speed	separately adjustable	
at 50 Hz about s /90°	4	10
Voltage	230/400 VAC	
Nominal current (control system)	8 A	
Braking moment (mechanical brake)	2.95 lbf ft	2.95 lbf ft
Duty cycle	30 % ED	
IP rating	IP 54	
Opening angle max.	180°	
Position control	Encoder	
Weight (without accessories)	66 lbs	121 lbs
Width of the door max.	4.92 ft	8.2 ft
Weight of the door max.	660 lbs	1320 lbs

Options

- Position Control

The AC-21 swing door operators are generally equipped with an integrated encoder. This assures an extremely precise positioning of the door. As an option the DICTAMAT 310-21 door operators can also be furnished for the use with separate limit switches.

- Mechanical brake

The standard AC-21 operators are equipped with a mechanical brake making sure that even in case of a power failure the door is stopped within the required distances. In case of doors to which the EN 12453 standard does not apply, the door operators can be furnished also without the mechanical brake.

- Electromagnetic clutch

All door operators with integrated mechanical brake impede a movement of the door without current. If the doors have to be moved manually in case of a power failure, the door operator can be furnished with an electromagnetic clutch.

- Accessories

Special accessories for customized specifications are available on demand.

- Forces

On demand the DICTAMAT 310-21 series is also available with other forces.

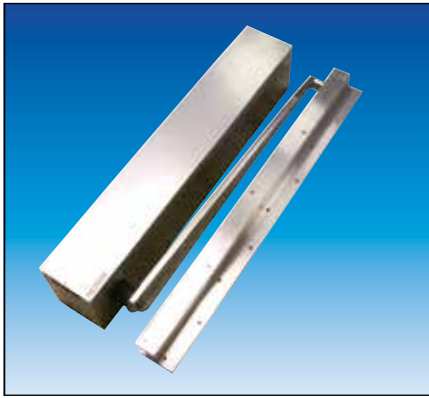

Components

The AC-21 swing door operators transmit the power to the door with the help of a specially designed lever. They are normally fixed to the lintel or the door frame. It is very important to assure a safe and solid fixing of the door operator as there result very high forces when the mechanical brake enters into action.

The following picture shows the components of an AC-21 door operator system for swing doors.

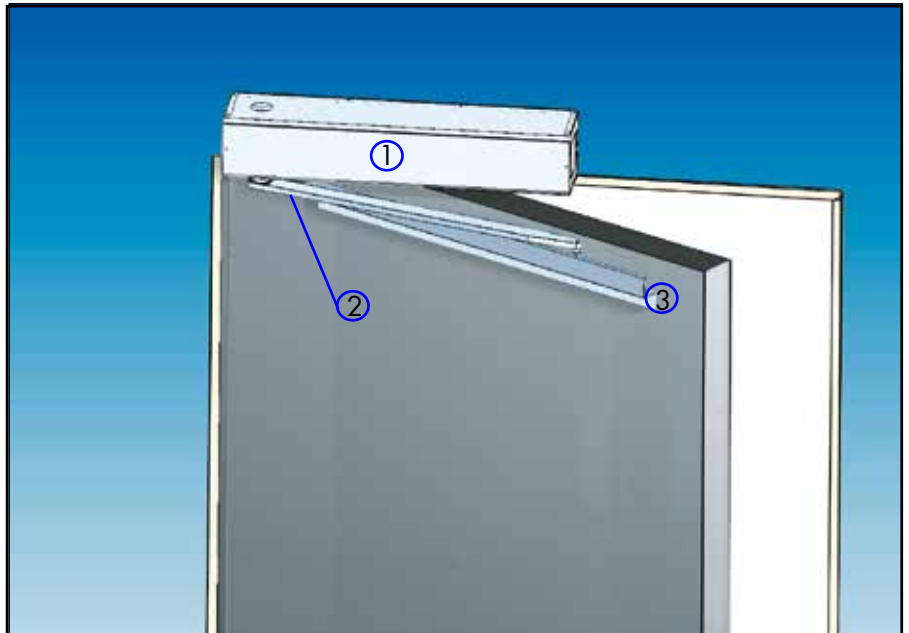

- ① Door operator
- ② Lever with roller
- ③ Two-piece slide channel

Components Included DICTAMAT 310-21

- Door operator: worm gear transmission with a 230/400 VAC three-phase motor and integrated mechanical brake, thermal cutout, 6.56 ft connection cable to the control system
- Lever with roller
- Slide channel for the lever to be fixed on the door (for power transmission)
- Integrated encoder

Additional Components

- Electromagnetic clutch

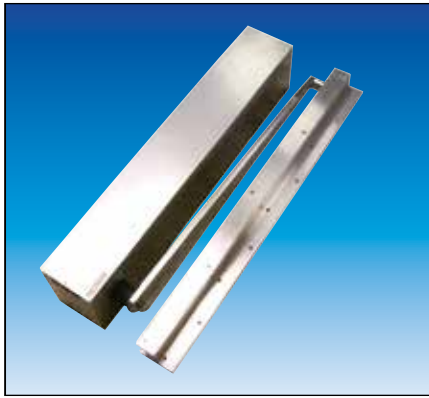

DICTAMAT 310-21

The DICTAMAT 310-21 is available in two executions: the standard type and the XXL type for very large doors. The XXL-type uses the same motor as the standard type, however with a much stronger gear transmission. Therefore, the XXL type is considerably longer than the standard type.

Dimensions

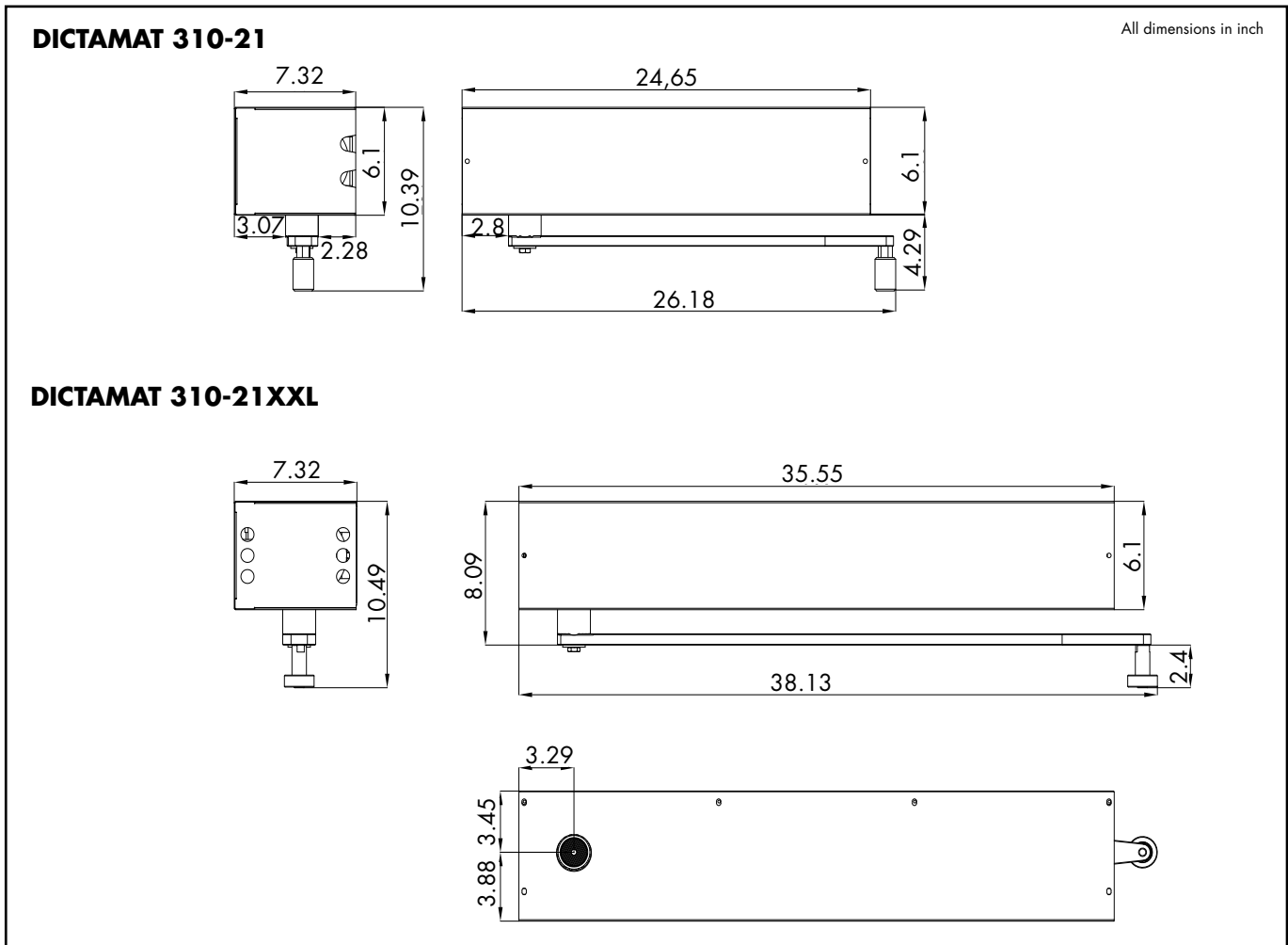

Order Information Door Operators

DICTAMAT 310-21	part no. 790800
DICTAMAT 310-21 XXL	part no. 790820

Order Information Control System

SQUARE 940-2 control system	part no. 706094-2
Information about the control system can be found beginning on page 04.037.00.	

Sliding Door Drive

DICTAMAT OpenDo

The DICTAMAT OpenDo is a compact door operator for single and double-leaf sliding doors of a maximum width of 62.99 inch. It is easy to install and the complete kit includes the rail. It is available for timber and glass doors.

This door operator is ideal for offices, surgeries, nursing homes, apartments for disabled persons etc.

It needs extremely little space and offers many operating options. The control system as well as the transformer are installed into a standard surface or flush-fitting switch box.

It offers very high safety due to the force reversal system controlled by a microprocessor. As soon as the door encounters an obstacle it will stop and then reverse, i.e. move in the opposite direction. The control system also automatically reduces the speed shortly before arriving at the final positions, thus offering additional safety and sparing the door and the mechanism.

Mounting is very simple due to the coordinated components. Placing into operation comprises an automatized teach-in run to learn the final positions. Also "programming" the control functions is very easy.

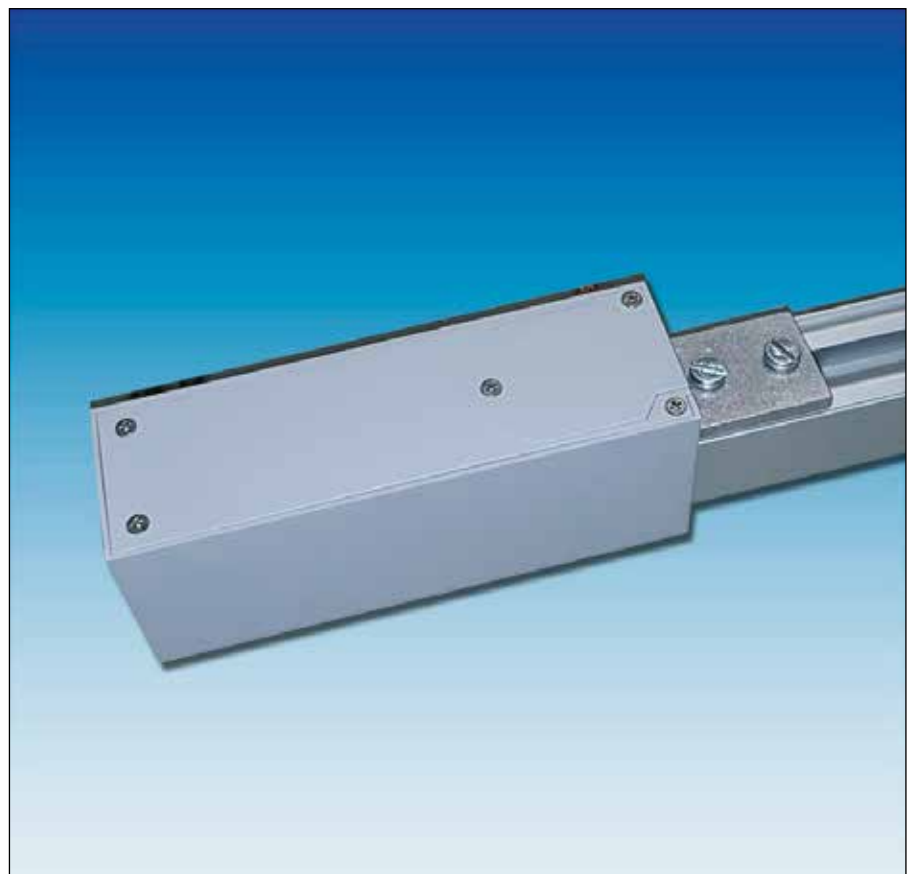

Overview

Door width (max.)	single-leaf doors: 62.99 in double-leaf doors: 41.65 in per leaf
Door thickness	timber: 0.75 - 1.89 in, glass 0.39 in (on demand also 0.47 in)
Door weight	max. 176 lbs, double-leaf doors: max. 88 lbs per leaf
Position control	"learns" the positions by teach-in run
Basic functions	OPEN, CLOSE (per impulse or automatically by automatic closing), reversing when recognizing an obstacle
Operation	standard: key or push-and-go; options: remote control, radar



Dimensions, Technical Data

The driving unit of the DICTAMAT OpenDo is very small. It just measures 5.71 x 2.17 x 1.77 inch.

The door drive is supplied complete with the rail. The rail can be fixed by means of the included brackets to the wall or from below directly to the ceiling.

Dimensions

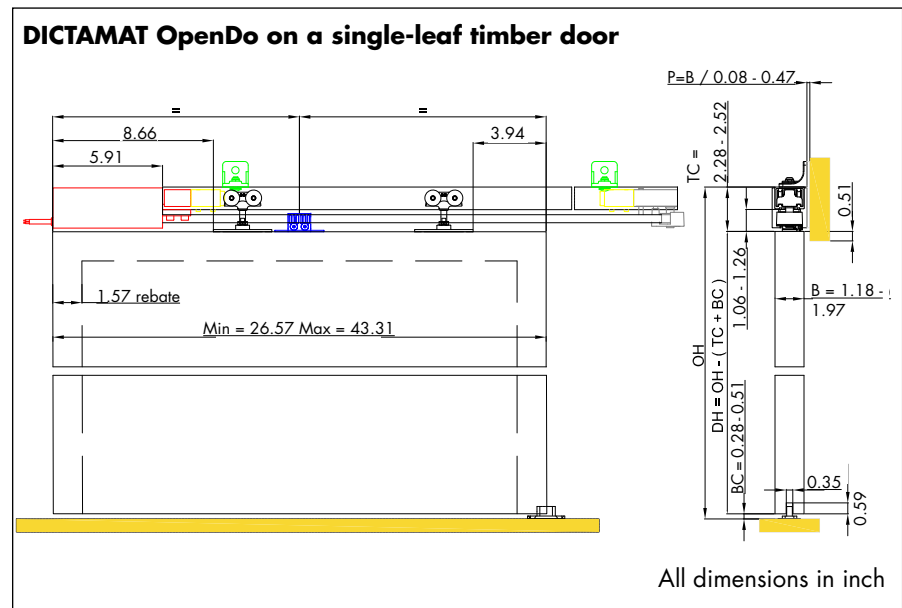

Technical Data DICTAMAT OpenDo

Door width	standard version for single-leaf doors: 26.57 in to 62.99 in standard version for double-leaf doors, per leaf 26.57 in to 41.65 in; both door leaves must have the same dimensions!
Door weight	single-leaf doors: max. 176 lbs double-leaf doors: max. 88 lbs/leaf
Door thickness	timber: 0.75 - 1.89 in, glass 0.39 or 0.47 in
Speed	max. 9.84"/s; adjustable, depends on door weight: 176 lbs => max. 7.87"/s; 132 lbs => max. 9.06"/s; 88 lbs => max. 9.84"/s
Hold-open time	adjustable between 5 and 30 seconds
Rated input voltage	100 to 240 V AC, 50 to 60 Hz
Motor rating	50 W
Safety	microprocessor controlled switch-off in case of obstacles
IP rating	IP 55
Operating temperature	-4° to +122 °F
Operational life	min. 400,000 cycles
Max. number of operations	up to 50 operations per hour

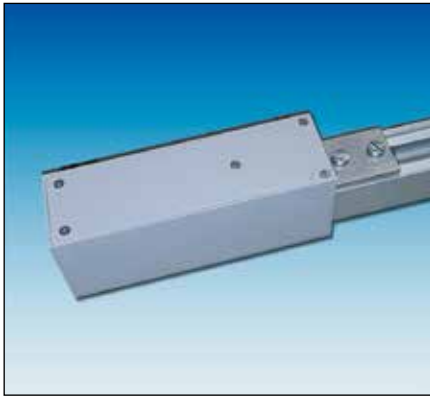

Operation Possibilities

The control system of the DICTAMAT OpenDo is extremely small. It can be fitted in a customary flush-fitting or surface switch box which has to be provided on site. The delivery of the DICTAMAT OpenDo includes a cover frame.

Besides the included switch-key for operating the DICTAMAT OpenDo, you also can connect e.g. large surface switches. These are usually combined with the automatic closing, i.e. the door will automatically close after the adjusted hold-open time.

The door can also be operated by remote control. An appropriate receiver and transmitter are available as additional option.

Functions, Operation Possibilities

The DICTAMAT OpenDo offers many different functions. They are adjusted in the control system by means of DIP switches (see photo).

You have to take into consideration that the functions may be different in continuous pressure operation and in impulse operation (see following table).

Opening and closing the door via remote control or motion detector is only possible if the impulse operation is adjusted.



Basic operation mode	Continuous pressure (Door moves only when the corresponding key is pressed.)	Impulse operation (Door opens/closes after shortly having pressed the switch-key.)
OPEN	only per switch-key	- per switch-key (standard) - push-and-go (pushing the door shortly by hand activates the door operator which will automatically open the door) - radar or remote control
CLOSE	only per switch-key	- per switch-key (standard) - automatic closing (door closes automatically after an adjustable time) - radar or remote control
Safety (detection of obstacles) in opening and closing direction	Stop	- reversing (the door stops and then moves in the opposite direction) - Stop: only possible, when no automatic closing has been adjusted
Door permanently open	Door remains open until the next CLOSE command.	Possible by key combination also when automatic closing is adjusted.
Moving the door in case of a power cut	Can be moved by hand with little effort.	



Components Included / Components

The delivery of the DICTAMAT OpenDo includes the rail and the accessories. The wheel hangers of the standard version are with slide bearings. However, when the operator is subject to heavy use, e.g. in restaurant kitchens, the version with AISI 316 hangers with ball bearings and rollers should be chosen.

On demand, a cover for the rail is available. In the order has to be specified how the rail is fixed (to the ceiling or to the wall).

Components Included DICTAMAT OpenDo

Standard version for single-leaf timber doors of up to 43.31 in width

Door operator with bracket and washers, power transformer 230 VAC/24 VDC for installation in flush-fitting or surface switch box (provided on site) (where required, together with the control system), control system with key OPEN/CLOSE for installation in flush-fitting or surface switch box (provided on site), idler pulley, door actuator, 13.45 ft of toothed belt

Aluminium rail (6.56 ft), 4 brackets in aluminium for fixing to the wall, 2 wheel hangers (hangers with slide bearings) with fixing brackets for screwing to the door, 1 floor guide, 2 final stopping devices for fitting into the rail

Standard version for double-leaf timber doors of up to 41.65 in width

Door operator, control system, idler pulley see above, 2 door actuators, 26.57 ft of toothed belt

Aluminium rail (2 x 6.56 ft), 4 brackets in aluminium for fixing to the wall, 4 wheel hangers (hangers with slide bearings) with fixing brackets for screwing to the door, 2 floor guides, 3 final stopping devices for fitting into the rail

Glass doors

On glass doors the door actuator(s) and the wheel hangers are fixed by gripping jaws instead of being screwed on. Also the floor guide is different. All other components are the same.

Options / Accessories

Version for heavy use

For heavy use we recommend the DICTAMAT OpenDo with wheel hangers in AISI 316 with ball bearings. They reduce friction considerably and the moving door produces much less noise.

Remote control: In case the DICTAMAT OpenDo shall be operated by remote control, you need a transmitter and a receiver. This can be installed, e.g. together with the second switch-key in a flush-fitting switch box.

Motion detector: Also a motion detector can trigger the OPEN command. This motion detector can be connected directly to the control system, without needing further components.

Cover for the rail: Depending on how the rail is fixed and on how thick is the door leaf different covers for the rail are available. They are simply clipped on the rail.

Versions

FI40: when the rail is fixed to the wall (wall fitting)

FI34: when fixed to the ceiling (soffit fix), max. thickness of the door leaf 1.97 in

FI38: when fixed to the ceiling (soffit fix), max. thickness of the door leaf 1.1 in

The covers are supplied in 6.56 ft pieces which have to be cut to length on site.

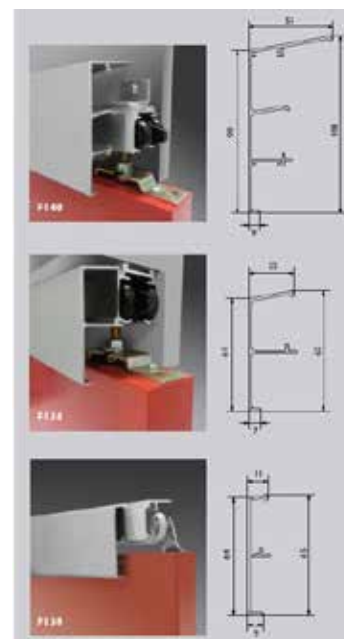

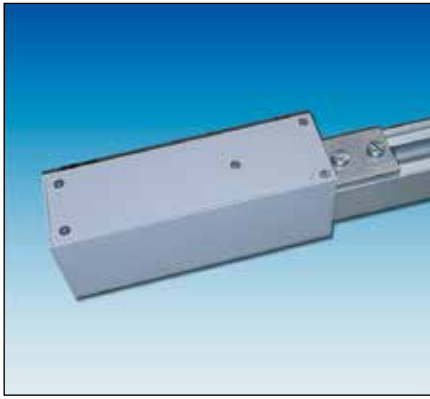

Order Information

As the DICTAMAT OpenDo comes together with the rail, different kits are available, depending on the type of the door (timber/glass), the width of the door and whether it is a single or double-leaf door.

In case the following order information doesn't show the version you need for your door, please contact us. We will be happy to help you.

Order Information

	Part number
DICTAMAT OpenDo for single-leaf timber doors up to 43.31 in, rail length 6.56 ft, aluminium rail, wheel hangers with slide bearings	710650
DICTAMAT OpenDo for single-leaf timber doors up to 43.31 in, rail length 6.56 ft, aluminium-rail, wheel hangers in AISI 316 with ball bearings	710651
DICTAMAT OpenDo for single-leaf glass doors (0.39 in thick) up to 43.41 in, rail length 6.56 ft, aluminium rail, wheel hangers with slide bearings	710652
DICTAMAT OpenDo for single-leaf timber doors up to 62.99 in, rail length 9.84 ft, aluminium rail, wheel hangers with slide bearings	710653
DICTAMAT OpenDo for double-leaf timber doors up to 43.31 in total width, rail length 2 x 6.56 ft, aluminium rail, wheel hangers with slide bearings	710654

Accessories

Remote control kit, including a receiver and one remote control	710660
Remote control OPEN / CLOSE	710661
Motion detector Eagle One	700389
Large surface hand switch, flush installation, stainless steel look	700194
Contactless large surface hand switch, flush installation	700188
Rail cover FI40 for rail fixed to the wall, length 6.56 ft	710665
Rail cover FI34 for rail fixed to the ceiling, length 6.56 ft	710666
Rail cover FI38 for rail fixed to the ceiling, length 6.56 ft	710667



Hinged Door Drive

DICTAMAT SPR

The DICTAMAT SPR is a small, economical but enormously powerful hinged door drive. It can be easily retrofitted. The door operator is available for 230 VAC as well as for 24 VDC. It works with a guide rail arm.

Normally, the opening command is given by means of a push-button or another control device (e.g. radar, radio). However, a push-and-go function can also be set. The door can be closed either automatically after an adjustable time (0 - 30 seconds) or also by push-button. If required, the drive can be upgraded with a set of rechargeable batteries so that emergency operation is possible in the event of a power failure.

A power interruption as integrated safety is standard. When closing, the operator reverses as soon as it encounters an obstacle. When opening, the movement is stopped. Further safety elements can be connected. The DICTAMAT SPR is supplied with a stainless steel cover.

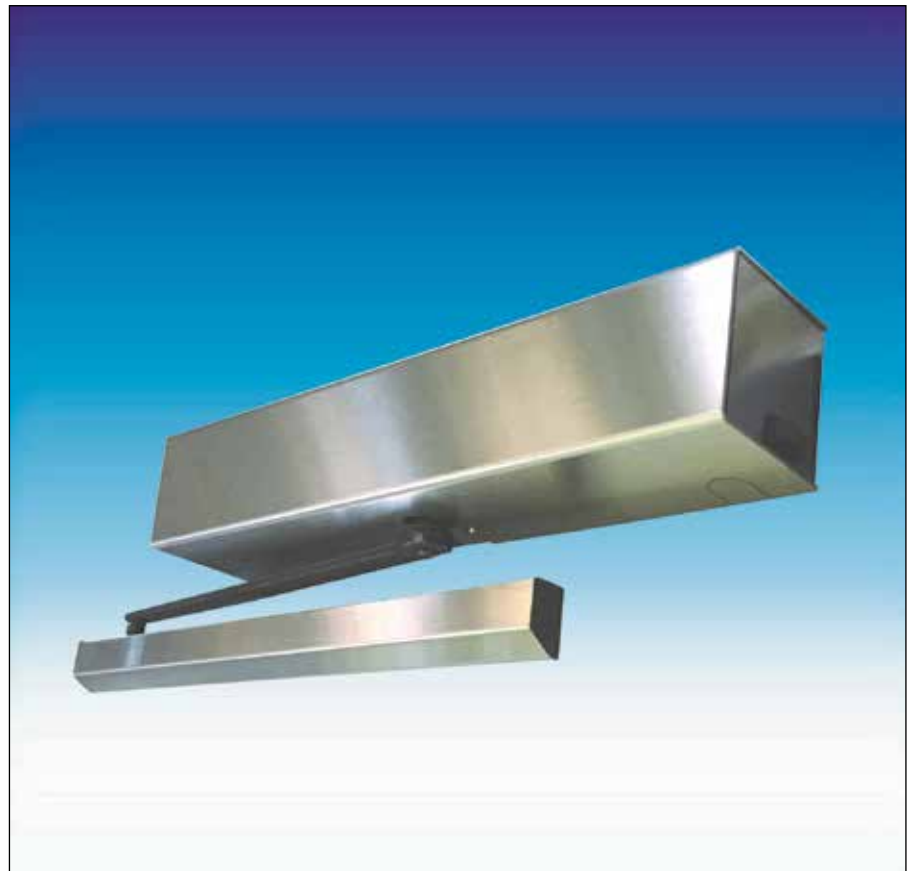

Overview

Width/Weight of door leaf	with 35.43 in door width max. 220 lbs, with 39.37 in door width max. 176 lbs.
Driving power	18.44 lbf ft
Appropriate for	frequent operation (up to 600 cycles per day, at 2/3 of the maximum weight)
Door opening angle	max. 100°
Functions	OPEN: Control device or Push and Go CLOSE: Control device or automatic closing delay Safety: reversing on closing, stop on opening



Dimensions, Technical Data

The DICTAMAT SPR transmits its power via sliding link arm as standard.
 A stop is integrated in the guide rail, which can be positioned individually for each application.
 For optical reasons an additional cover made of stainless steel is supplied for the rail.

Dimensions

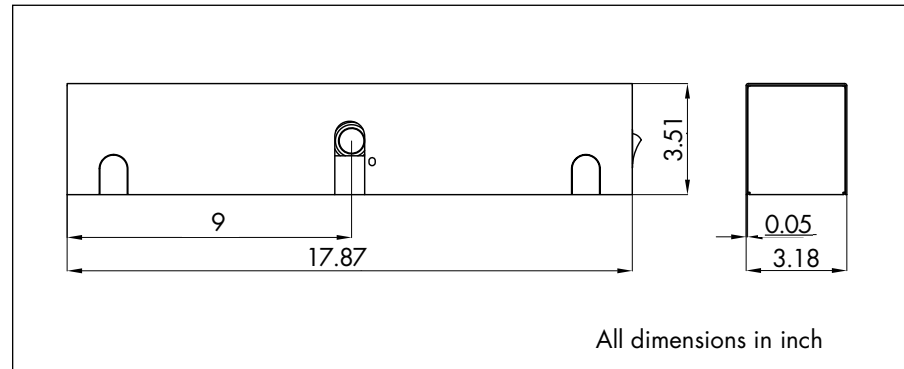
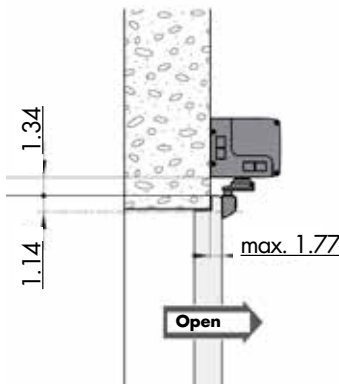

Technical Data DICTAMAT SPR

Rated input voltage	24 VDC	230 VAC / 50/60 Hz
Consumption	3 A	0.5 A
Motor rating	120 W	
Torque	18.44 lbf ft	
Power supply for additional components	24 VDC / max. 0.3 A	
Opening time	min. 3 seconds/90°, max. 6 seconds/90° (adjustable)	
Closing time	min. 4 seconds/90°, max. 7 seconds/90° (adjustable)	
Hold-open time with closing delay	0 - 30 seconds (adjustable)	
Door width / Door weight	with 35.43 in door width max. 220 lbs, with 39.37 in door width max. 176 lbs - see diagram on the left	
Duty cycle	80 %	
IP rating	IP 30	
Operating temperatures	14 °F to max. 122 °F	
Position control	encoder, teach-in via automatic teach-in run	

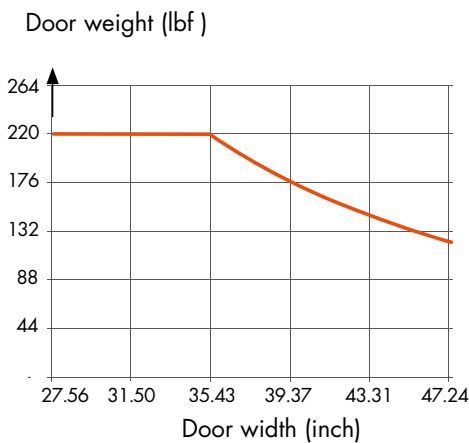

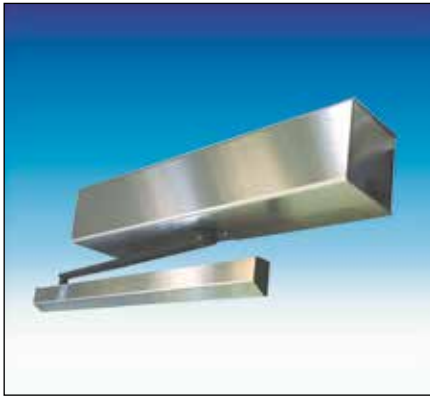

Operating Options / Safety

The control of the DICTAMAT SPR is integrated in the housing of the door operator.

In case of power failure the door with drive can be moved by hand easily. Optionally, a set of rechargeable batteries is available so that the door drive can still perform approx. 10 opening/closing movements even in the event of a power failure.

If required, a radar can be connected so that the door opens automatically when a person is within the detection range of the radar.

Functions, Operating Options

The DICTAMAT SPR offers many operating and setting options (see table below).

A safety function is integrated in both the opening and closing direction, so that additional safety devices are only necessary if required by the location.

If needed, a switch on the outside of the DICTAMAT SPR housing can be used to keep the door permanently open, e.g. if something has to be transported through the door.

Basic operating mode	Explanation
OPEN command	<ul style="list-style-type: none"> - by push button (standard) - Push-and-go (when briefly pushing the door by hand, this activates the door operator and it opens the door automatically; adjustable in the standard version) - Radar or radio as options (requires additional components)
CLOSE command	<ul style="list-style-type: none"> - by push button (standard) - Automatic closing (door closes automatically after an adjustable time) - Radar or radio as options (requires additional components)
Safety (obstacle detection) during opening	If the door opens and encounters an obstacle, the door stops immediately.
Safety (obstacle detection) during closing	If the door closes and encounters an obstacle, the door reverses immediately, i.e. it opens again.
Door permanently open	The operator can be switched off completely by means of the button on the outside of the DICTAMAT SPR housing. After switching on, the drive then performs the following two movements (closing and opening) at crawl speed (checking the end positions).
Moving during power failure	The drive is smooth-running when de-energised, so that the door can be opened/closed by hand without any effort in case of power failure.

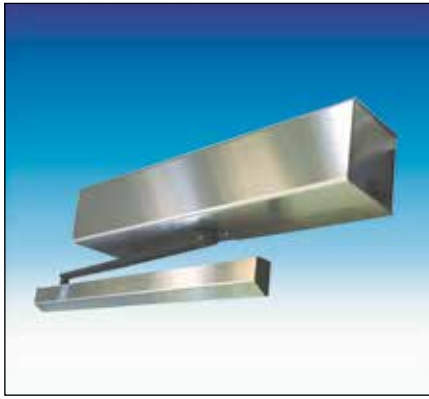

Scope of Delivery / Components

The DICTAMAT SPR is supplied complete with arm and guide rail and cover.
Additional safety and operating elements can be connected if required.

Components Included DICTAMAT SPR

Hinged door operator with pre-assembled mounting plate

Arm, guide rail

Mounting tray and stainless steel cover for the drive unit

Stainless steel cover for the guide rail

Order Information

DICTAMAT SPR with guide rail, 230 VAC,
including control system

part no. 710140

DICTAMAT SPR with guide rail, 24 VDC,
including control system

part no. 710141

Safety and Operating Equipment For DICTAMAT Door Operators

Depending on the application of the DICTATOR DICTAMAT door operator there are needed different operating elements. These can be simple hand switches, key switches, pulling switches but also remote control or motion detectors.

In addition usually appropriate safety equipment is required, either to protect people and/or material from damage.

On the following pages you will find a choice of operating and safety equipment. In case of special requirements please ask us. In choosing the safety equipment the demands of the applying safety standards have to be kept in mind, e.g. EN 12453.

Please observe the maximum capacity of the binders in the control system. The power consumption of the connected devices must not exceed this value. An additional power pack should be ordered if necessary. (Please see the chapter Fire Door Control Solutions in the DICTATOR catalog).

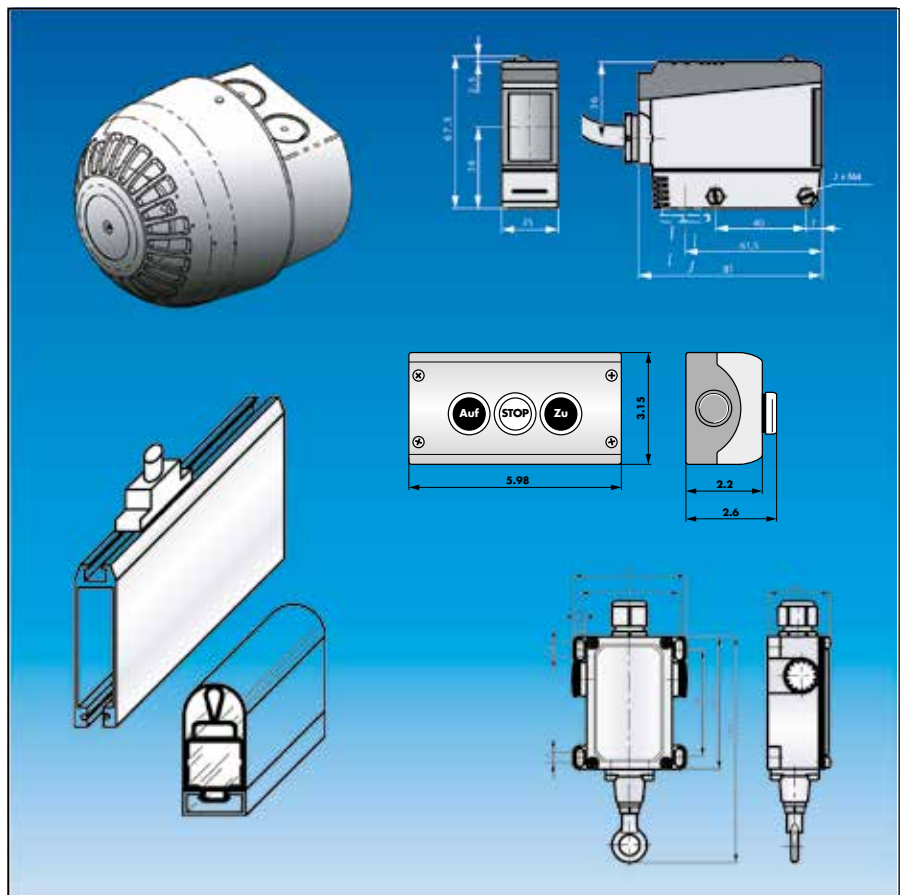

Summary

Acoustic and optical warning devices	page	04.056.00
Light barriers	page	04.057.00
Contact switches / safety contact switches	page	04.060.00
Motion detectors	page	04.065.00
Remote control	page	04.066.00
Switches	page	04.067.00
Ex-proof operating and safety elements	page	04.072.00

Warning Flashlight with Integrated Siren

Description

The warning flashlight is used to caution people against the movement of automatic doors. Almost all control systems are provided with a relay contact indicating the movements of the door, some even with the possibility to start the flash light before the delayed movement of the door.

The LED flashlight also features a siren. You can choose between 32 different warning tones. The volume can be adjusted by means of a potentiometer. If required, it is possible to completely shut off the siren.

Dimensions

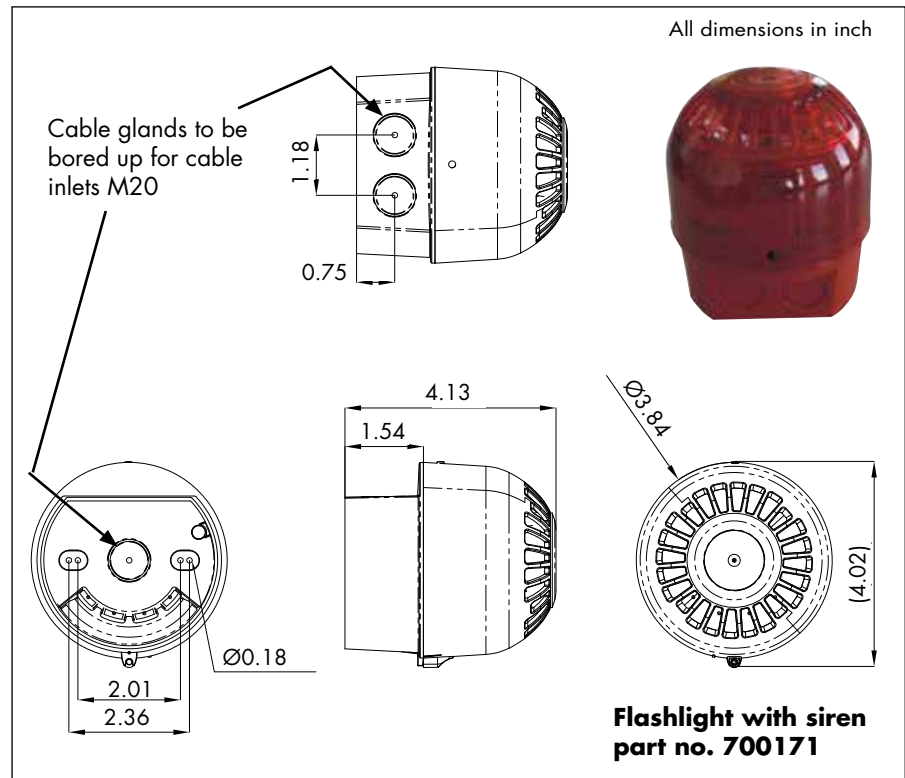

Technical Data

Operating voltage	17 - 60 VDC
Power consumption	flashlight: 5 mA siren: 4 - 45 mA (depending on the volume, the chosen sound and the input voltage)
IP rating	IP 65
Cable inlet	two laterally in the base and one in the bottom, intended for M20 cable inlets
Flashing frequency	1 Hz
Volume	94 - 106 dBA in 3.3 ft distance, can be reduced by the integrated potentiometer or completely shut off
Warning tone	32 different tones adjustable by DIP switches
Material / Colour	impact resistant polycarbonate / red
Operating temperature	-13 °F to +158 °F

Order Information

Flashlight with integrated siren, red	part no. 700171
---------------------------------------	-----------------

Photoelectric Barriers: Reflecting Photocell up to 32.81 ft

Description

Photoelectric barriers help to detect obstacles in the immediate door surroundings. Whenever the photoelectric barrier is actuated the door will either stop or reverse the direction of movement. In order to increase safety you should install several photoelectric barriers on a door at different heights above the floor. Please observe the relevant safety regulations.

For normal industrial doors with an opening width up to 32.81 ft we recommend our reflecting photoelectric barrier part no. 700116. Only the emitter of the light beam requires electrical connection. The fixing bracket allows for an adaption of the angle of the light beam up to 30°, permitting to adjust it perfectly to the reflector. This photoelectric barrier is suitable for a very large range of different voltages.

Dimensions

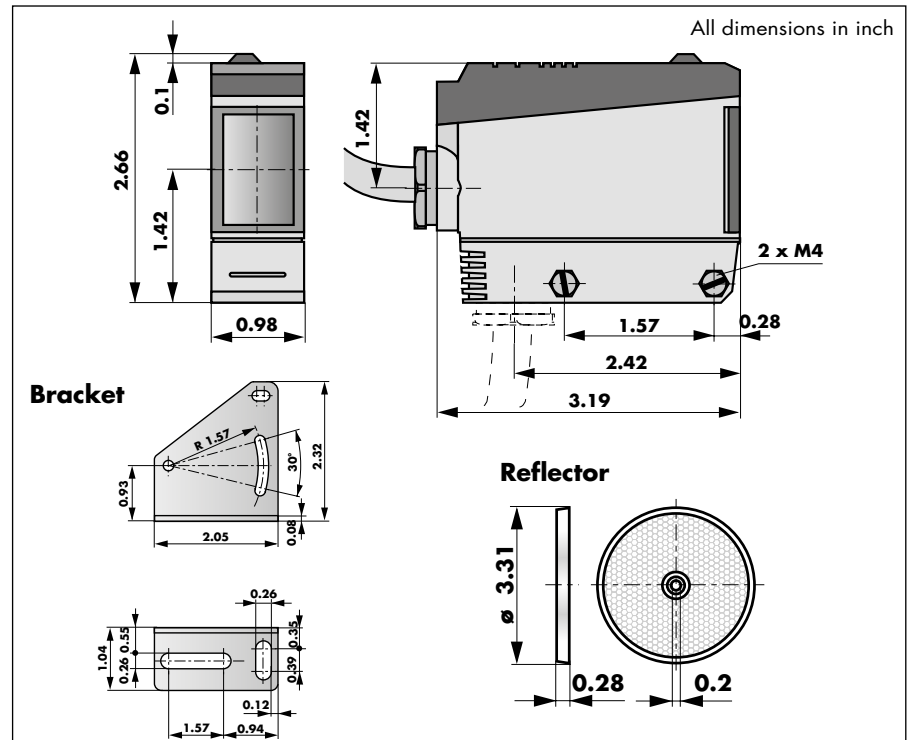

Technical Data

Voltage	10.8 - 264 VDC / 21.6 - 264 VAC (45-65 Hz)
Power consumption	≤1.5 W (60 mA) / 2.0 VA
IP rating	IP 67
Cable inlet	PG 13,5
Potential-free relay contact (make-break)	3 A / 30 VDC 2 A / 250 VAC
Operating temperature	-13 °F to +131 °F
Maximum range	32.81 ft
Light source / Beam spot diameter	880 nm / 11.02" at 13.12 ft
Type of light	infrared
Material of the casing / Colour	reinforced PC/ grey-black
Classification as per EN 12453	"C"

Order Information

Photoelectric barrier with reflector ø 3.15", up to 32.81 ft part no. 700116

Photoelectric Barriers: One-Way Light Barrier up to 98.43 ft

Description

For large doors DICTATOR furnishes a one-way photoelectric barrier up to 98.43 ft range. It consists of a transmitter and receiver to be installed at the opposite sides of the door opening. Whenever the light beam is shattered the electrical contact of the receiver is switched over (make or break).

In order to achieve a faultless operation it is imperative that both transmitter and receiver are properly aligned (detection angle +/-4°). If two photoelectric barriers are installed on the same door the two transmitters should be placed one on each side, in order to avoid any interference of the photoelectric barriers.

Dimensions

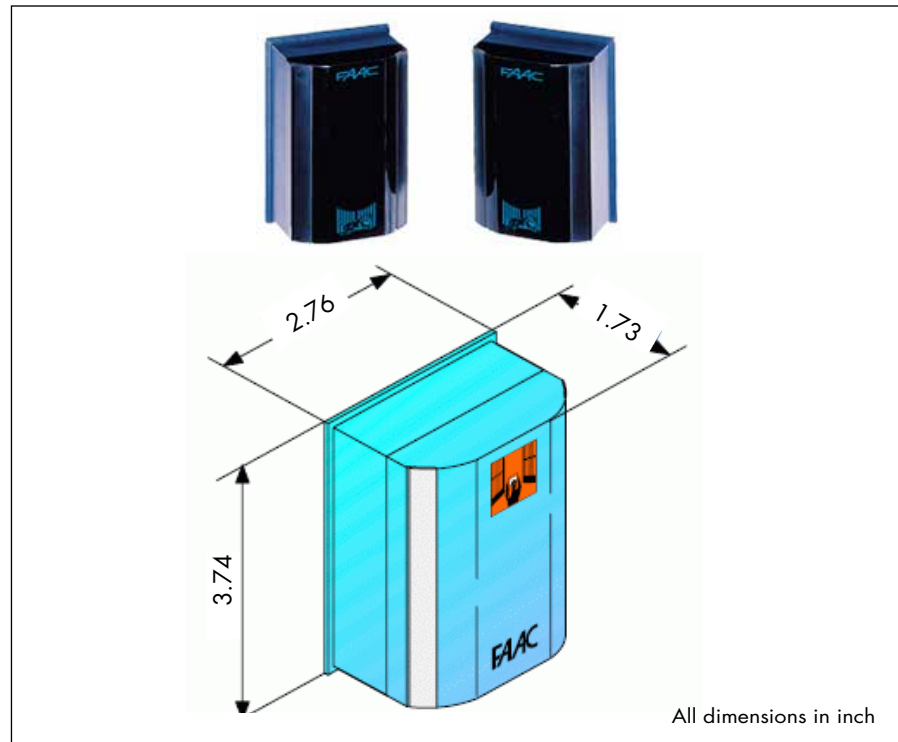

Technical Data

Voltage	24 VDC (19 - 35 VDC) 24 VAC (21.5 - 25.5 VAC)
Power consumption	transmitter 20 mA, receiver 30 mA
IP rating	IP 54
Cable inlet	at the back and the side, \varnothing 0.87"
Relay contact	make/break contact 100 mA / 24 VDC
Operating temperature	-4 °F to +131 °F
Maximum range	98.43 ft
Type of light	infrared
Material of the casing / Colour	plastics / dark blue
Classification as per EN 12453	"C"

Order Information

Photoelectric barrier, up to 98.43 ft	part no. 700360
---------------------------------------	-----------------

Photoelectric Barriers: Ex-proof photocell up to 98.43 ft

Description

EU type-examination certificate (no. 93096) according to EN 954-1 for explosion-proof photoelectric barrier with safety relay: **category 4**

In hazardous areas only devices tested according to the ATEX standard may be used. The ex-proof photoelectric barrier is made up of a transmitter and a receiver. Furthermore a safety relay with a potential-free contact is required to pass on signal to the control system of the door drive.

Both transmitter and receiver are provided with a 32.81 ft cable. The safety relay has to be installed outside the hazardous area.

The status of the photoelectric barrier is indicated by LEDs on the receiver.

ATEX-certificate: DMT 99 ATEX 056/N1

Dimensions

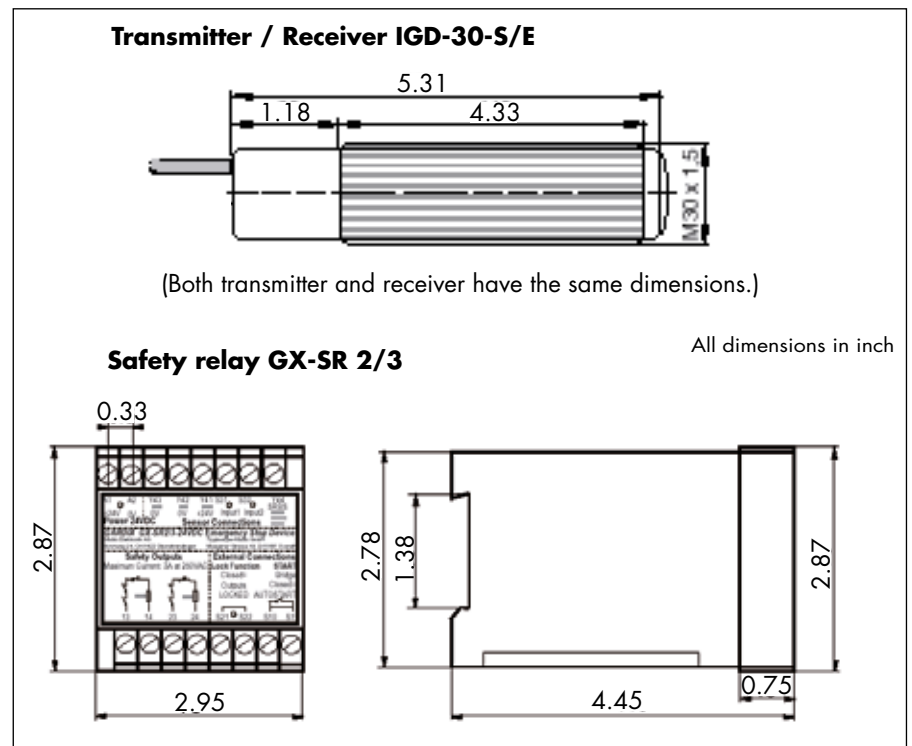

Technical Data

Voltage	24 VDC (20 - 28 VDC)
Power consumption	transmitter 30 mA, receiver 50 mA safety relay 200 mA
Ex-rating / IP rating	EEx d IIC T6, zones 1, 2, 20/21, 22 / IP 67
Connection cable (pre-wired)	32.81 ft (on demand up to 109 yd)
Relay contact (of the safety relay)	break contact, max. 750 VA/3 A at 250 VAC max. 100 W/3 A at 30 VDC
Operating temperature	-4 °F to +140 °F
Maximum range	1.64 to max. 98.43 ft
Type of light / Beam spot diameter	infrared 880 nm
Material of the casing / Colour	M30 brass, nickel plated
Classification as per EN 12453	"C"

Order Information

Photoelectric barrier IGD-30-S/E	part no. 700370
Safety relay GX-SR 2/3	part no. 700373

Safety Contact Edge

Function

Contact edges on doors protect persons and material. As soon as the contact edge is actuated, the door either stops or opens again.

The **safety contact edge** consists of an aluminium C-profile and a rubber profile with integrated switching element. It is delivered in the required dimension. If two contact edges are installed on a door, one of them has to be a so-called transit edge without final resistor. It is provided with a 8.2 ft cable on both sides. The current from the **evaluation device** passes through this edge to the final edge. The evaluation device controls whether the contact is closed or whether the safety circuit has been interrupted, i.e. the contact edge has been actuated.

Power is supplied to the contact edge via a **power guide rail with WLS helical cable system**, which is mounted either on top of the door or in the area of the door rail. Two junction boxes must be installed for the electrical connection: one fixed to the wall and one on the door.

EU type-examination certificate according to EN ISO 13849-1

Registration no. 44 205 13031820 for safety contact edge with evaluation device: **category 3**

Dimensions Safety Contact Edge

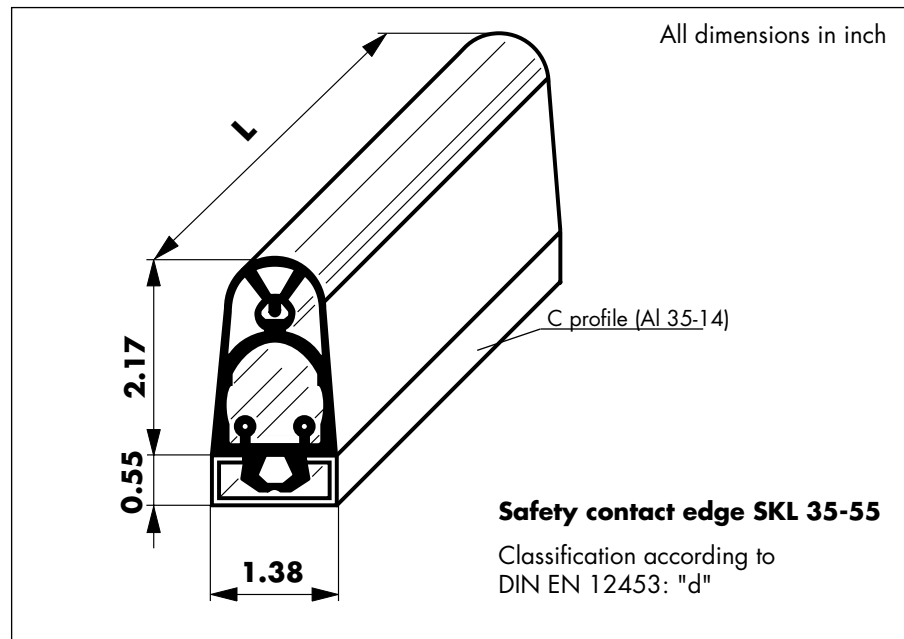

Technical Data

Voltage evaluation device	230 VAC ±10 %, 50 Hz, 24 AC/DC ±10 %
Power consumption evaluation device	3.5 VA/230 V, 1.5 W 24 VDC, 1.2 VA 24 VAC
Relay contact evaluation device	make contact (NO)
IP rating of contact edge	IP 65
Operating temperature	14 °F to 131 °F
Actuation force / Switching angle	9.9 lbf (at 0.39 inch/s) / 2 x 45°
Material contact edge	TPE

Safety Contact Edge - cont.

Dimensions Evaluation Device

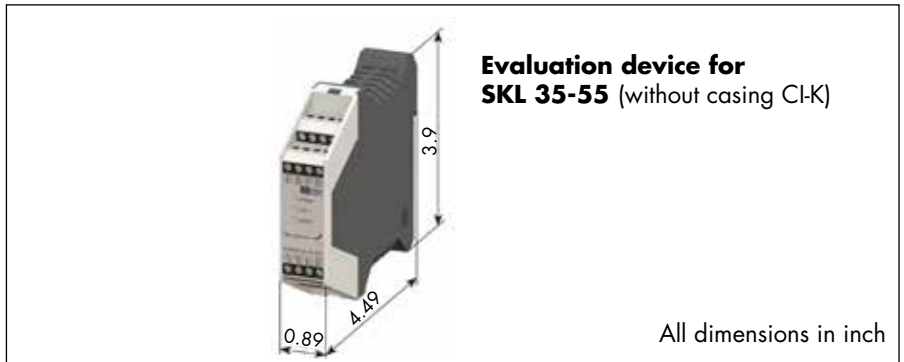

Dimensions WLS Helical Cable System

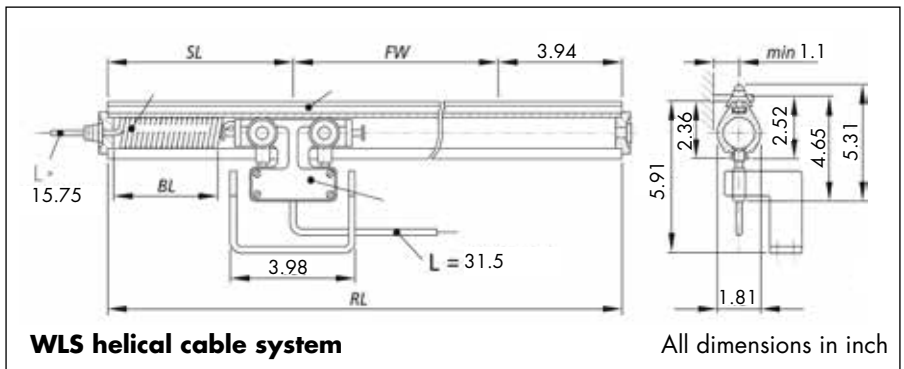

The current is transmitted via the WLS helical cable system. It consists of the WLS profile tube and an abrasion-resistant and extremely dimensionally stable helical cable with carriage that is matched to the profile.

The total length (RL) of the WLS helical cable system is calculated as follows:

$$RL = FW + SL + 0.33 \text{ ft}$$

Travel distance FW max. [ft]	Length of profile tube RL [ft]	Space required for helical cable SL [ft]
4.92	6.56	0.98
5.25 - 8.2	9.84	1.31
8.53 - 11.48	13.12	1.31
11.81 - 14.11	16.4 (6.56 + 9.84)	1.97
14.44 - 17.39	19.69	1.97
17.72 - 20.01	22.97 (9.84 + 13.12)	2.62
20.34 - 23.29	26.25 (13.12 + 13.12)	2.62
23.62 - 26.25	29.53 (9.84 + 19.69)	2.95
26.57 - 29.53	32.81 (13.12 + 19.69)	2.95

Order Information

Safety contact edge SKL 35-55, terminal edge incl. aluminium profile, base price	part no. 700785
SKL 35-55, transit edge incl. aluminium profile, base price	part no. 700786
Safety contact edge SKL 35-55, price per cm (= 0.39 in)	part no. 700787
Evaluation device for SKL 35-55, 230 V / 24 V AC/DC	part no. 700788
Casing CI-K, 3.94 x 6.3 x 5.71 inch (wxhxd), IP 65	part no. 040585
Conductor rail for WLS helical cable system incl. fastening set, assembled in the length suitable for the travel distance	part no. 700794

Safety Sensor for Industrial Doors

Description



The LZR safety sensor is the optimum solution to ensure safety in the danger areas of doors. As a type E protection device according to EN 12453 it represents the highest possible safety level that makes sure nobody can get into the area of the moving door. Therefore, no other safety devices are needed.

The safety sensor offers the possibility to adjust two separate detection areas during opening and closing and in front of the door four planes of detection with variable depth.

The mounting is very easy as there is only one device to install. The detection ranges are set with an infrared remote control. Three visible laser points make the alignment of the sensor very simple.

LEDs of different colours indicate the state of operation, errors and the states of the relay exits.

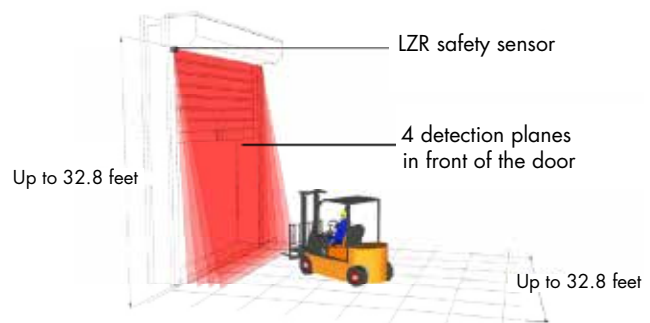

Technical Data

Safety categories inter alia:
 EN 954-1: category 2
 EN 13849-1:2008: Performance level "c"
 EN 12454: type E

Part no.	700384	700385
Max. detection range	16.4 x 16.4 ft	32.8 x 32.8 ft
Power supply	10 - 35 VDC at the sensor terminal	
Power consumption	< 5 W	
Response time	typ. 20 ms; max. 80 ms	
Output	2 electronic relays (polarity free) <i>max. switching voltage 35 VDC/24 VAC</i> <i>max. switching current 80 mA (resistive)</i>	
Dimensions	4.92 (w) x 3.66 (d) x 2.76 (h) inch (mounting bracket + 0.55 inch)	
Material of casing	PC/ASA	
Colour	white	black
IP rating	IP 65 (not directly with a high-pressure cleaner)	
Temperature range	-22 °F to +140 °F (if powered)	
Humidity	0 - 95 % non-condensing	
Technology	laser scanner, time-of-flight measurement	

Components Included

Safety sensor with mounting bracket and 32.8 ft cable

The infrared remote control has to be ordered separately when needed.

Order Information

LZR-i110 safety sensor, max. detection range 16.4 x 16.4 ft	part no. 700384
LZR-i100 safety sensor, max. detection range 32.8 x 32.8 ft	part no. 700385
Infrared remote control for setting the safety sensor	part no. 700366

Safety Contact Edge

Description

Safety contact edges are used to secure the movement of hinged doors. They are installed directly on the door leaf. The type depends on the width of the door and the height at which the contact edge is mounted.

The safety contact edge 4 Safe meets the requirements of the standard DIN 18650, when being dimensioned and mounted correctly. It not only secures the moving range of the door leaf but also the squeezing and shearing edges. To provide safety during both opening and closing of the door you need two safety contact edges per door.

Configuration

The safety contact edge is made from two components: the mounting profile and the sensor modules. The number of sensor modules needed depends on the height of mounting and the width of the door. When the door is not wider than 43.31" and the safety contact edge installed at 74.8" height on the door, two modules are sufficient to ensure the complete moving range of the door. In case the safety contact edge has to be mounted at less than 74.8" height, please contact our technical department.



Safety categories inter alia:

EN 954-1: category 2
EN 13849-1:2008: Performance level "c"

The names of the types indicate the width of the door the safety contact edge is designed for - always presumed the installation will be at a minimum height of 74.8". The mounting profile of the safety contact edge 700 - 1100 mm/27.56 - 43.31" is, if necessary, shortened on site to match the door width. Doors being 700 to 1100 mm/27.56 - 43.31" wide need the same amount of sensor modules. The mounting profiles are delivered with the sensor modules already installed.

The safety contact edge includes an integrated monitoring thus enabling a connected door drive control system to check whether the safety contact edge is working or defect.

Technical Data

Voltage	12 - 30 VDC / 12 - 24 VAC (50 - 60 Hz)
Power consumption	65 mA at 24 VDC, 120 mA at 24 VAC
IP rating	IP 53
Relay contact	2 potential-free contacts (relay)
	max. 42 VAC/DC; max. 1 A (switching current)
	30 W(DC) / 60 VA(AC) (max. switching capacity)
Input	1 potential-free optocoupler
Operating temperature	-13 °F to +131 °F
Detection range	depending on mounting height/number of modules
Material of casing / Colour	ABS and aluminium / anodized alu, black

Order Information

Safety contact edge 4Safe L 700 - 1100 mm/27.56 - 43.31"	part no. 710133
Safety contact edge 4Safe L 1200 mm/47.24"	part no. 710134
Safety contact edge 4Safe L 1300 mm/51.18"	part no. 710135
Safety contact edge 4Safe L 1400 mm/55.12"	part no. 710136
Safety contact edge 4Safe L 1500 mm/59.06"	part no. 710137
Flexible cable guide	part no. 710276

Finger Guard Blind

Description

The finger guard blind is designed to secure the secondary closing edge of hinged doors. It prevents fingers to become squeezed between door and frame.

The finger guard blind is fixed to the door and the frame. An integrated spring tightens it constantly. As soon as the door is opened the blind is extended and covers the secondary closing edge. The maximum extension is 10.24".

The blind is made from black coated linen being washable.

The total length of the blind is 75.79". It is not possible to shorten it.

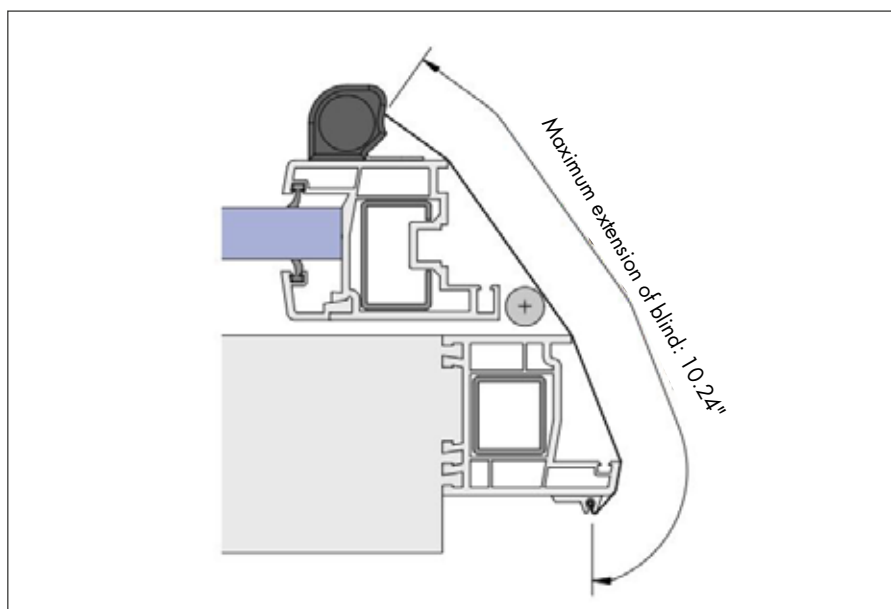
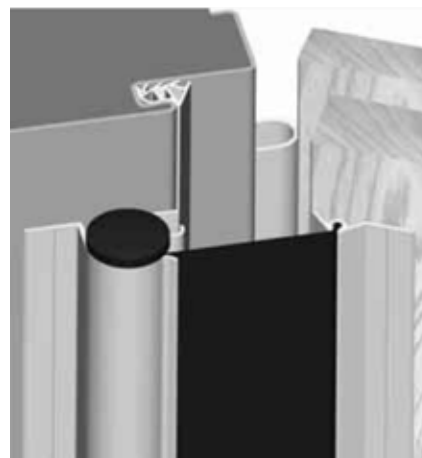

Technical Data

Standard length	75.79"
Maximum extension of blind	10.24"
Material of casing	aluminium AlMgSi 0,5 F22, natural
Material of blind	coated linen, washable, black

Order Information

Finger guard blind for hinged doors to secure the secondary closing edge	part no. 710132
--	-----------------

Motion Sensor - Eagle One Radar Motion Sensor

Description

Motion sensors are ideal to set off an OPEN-impulse on highly frequented doors, combined with an automatic closing. As soon as a moving object enters the detection range of the motion sensor, the DICTAMAT door drive will open the door. After the preset hold-open time has expired, the door closes automatically.

The Eagle One radar motion sensor has a very large detection range, also of laterally approaching movements. It only realizes approaching movements and ignores withdrawing ones. The maximum mounting height is 13.12 ft. It can be mounted on the wall as well as to the ceiling. When mounting the motion sensor on the side of the hinges (of a hinged door) it is mounted on the rotation axis.

With the help of a separately available infrared remote control the adjustments can be done quickly and very precisely.



Technical Data

Voltage	12 V to 24 VDC +30 % / -10 % 12 V to 24 VAC ±10 % (50 - 60 Hz)
Power consumption	< 2 W (VA)
Cable inlet	with 8.2 ft connection cable
Potential-free relay contact	make-break contact max. 30 W (DC) / max. 60 VA (AC)
Operating temperature	-4 °F to 131 °F
Detection range	13.12 ft (w) x 6.56 ft (d) at 7.22 ft installation height or 6.56 ft (w) x 8.2 ft (d) at 7.22 ft installation height
Material of casing / Colour	ABS / black
Dimensions (w x h x d)	4.72 x 3.15 x 1.97 inch

Order Information

Eagle One radar motion sensor	part no. 700389
Remote control to adjust the sensor	part no. 700366

Remote Control - with 2 Channels

Description

A remote control is recommended to operate doors with a DICTAMAT door operator e.g. when the door is mainly passed by vehicles. The basic and most economic solution is the remote control 868. It is made up by the radio receiver and one or several hand transmitters.

The antenna for receiving the radio signals is fitted into the casing of the receiver.

Dimensions

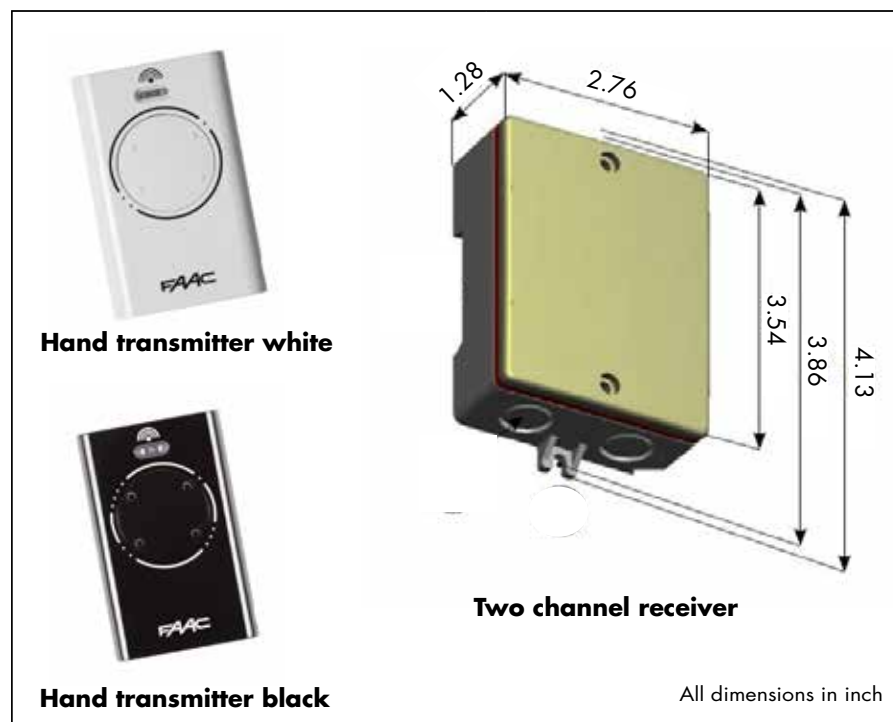

Technical Data

Voltage	24 VDC
Power consumption	100 mA
IP rating receiver	IP 44
Relay output	2 pieces, contact NO (1 x pulse circuit, 1 x pulse or dedicated (adjustable))
Frequency	868.35 MHz +/-2
Number of codes	250 can be stored
Operating temperature	-4 °F to 131 °F
Range (effective radius) (max.)	164.04 ft (in unobstructed areas)
Dimensions	receiver 2.76 x 4.13 x 1.28 inch

Order Information

Radio receiver, two channel, XR2 868C	part no. 700386
Hand transmitter XT2 868 SLH LR white (two channel)	part no. 700387
Hand transmitter XT2 868 SLH LR black (two channel)	part no. 700388

Push Button Switches

Description

DICTATOR furnishes a range of different push button switches to operate the DICTAMAT door operators. Normally a switch with two or three push buttons is used (OPEN/CLOSE or OPEN/STOP/CLOSE). The hand switches shown on this page are provided with the following **contacts**:

OPEN, CLOSE make contact (NO)

STOP break contact (NC) or make contact (NO) (depending on the type of the used control system)

Dimensions of the Push Button Switches

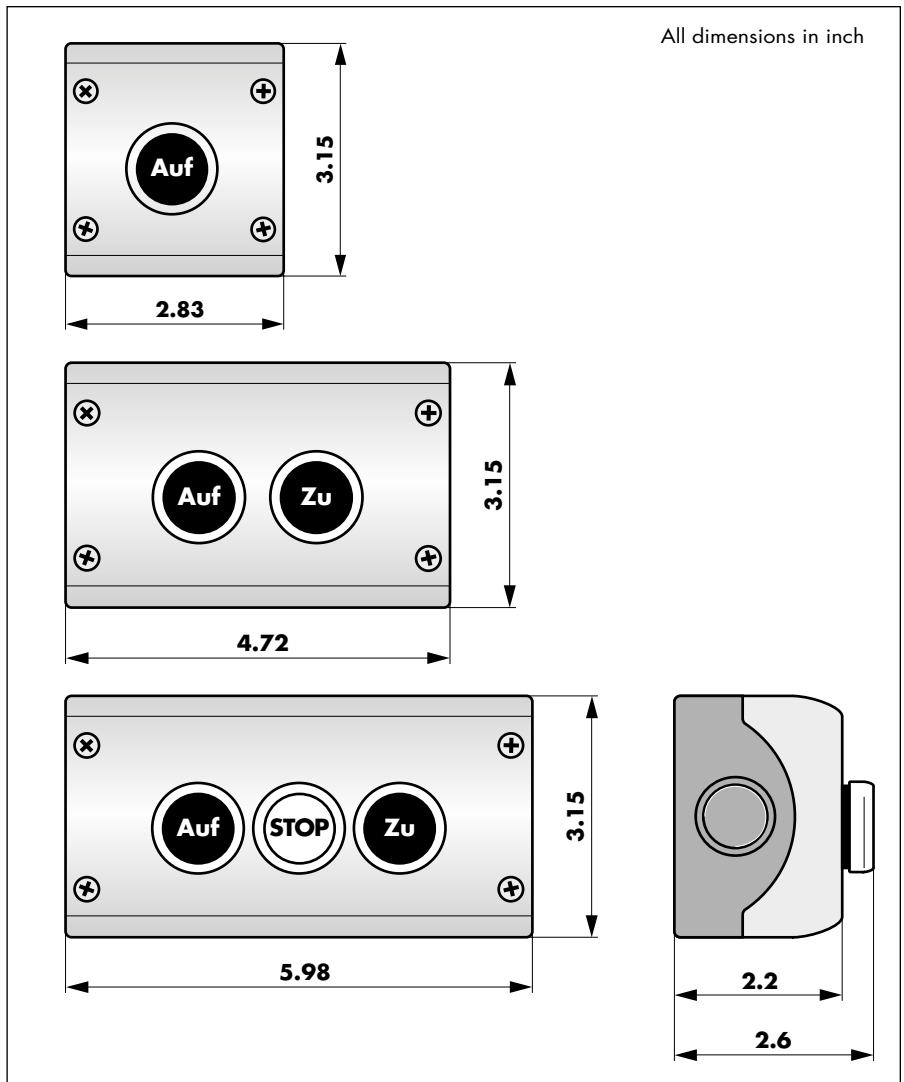

Technical Data

IP rating	IP 67
Operating temperature	-13 °F to +158 °F

Order Information

Push button switch OPEN (make contact, NO)	part no. 700185
Push button switch OPEN - CLOSE, (2 make contacts, NO)	part no. 700117
Push button switch OPEN-STOP-CLOSE (STOP = break contact, NC)	part no. 700142
Push button switch OPEN-STOP-CLOSE (STOP = make contact, NO)	part no. 700147

Key Switch

Description

A key switch is used whenever the use or the operation of the door is restricted to certain persons. The key switches offer only two operating possibilities: OPEN and CLOSE. Is the key switch part of a complete locking system the key switches can be furnished with a half profile cylinder, to be replaced with one belonging to the locking system.

Contacts:

OPEN, CLOSE make contact (NO)

Dimensions Key Switch

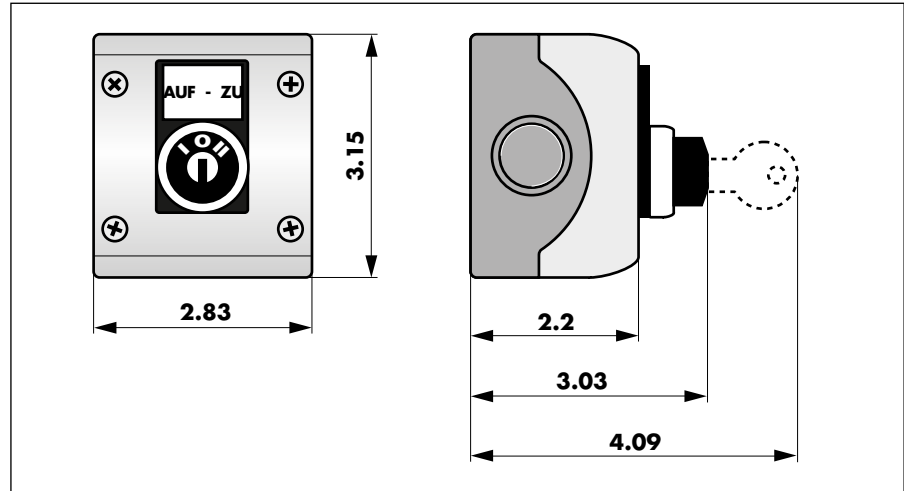

Dimensions Key Switch with Half Profile Cylinder

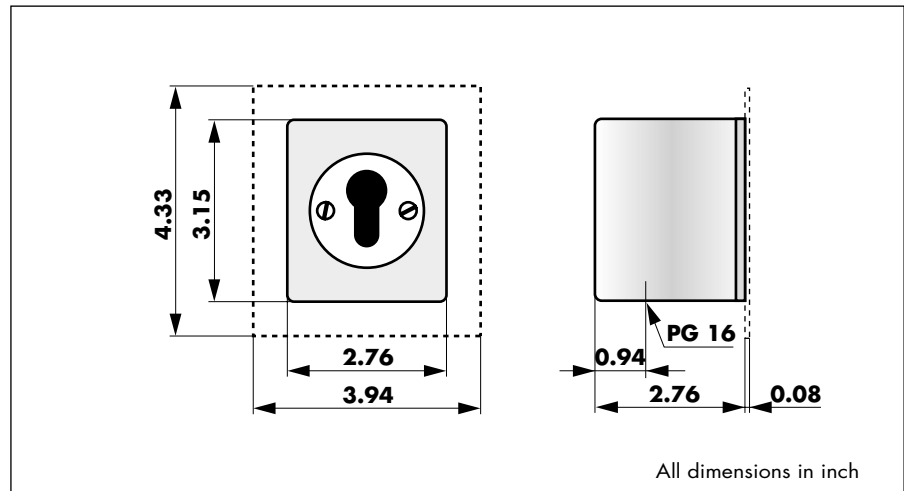

Technical Data

IP rating key switch	IP 67
IP rating key switch with half profile cylinder	IP 54
Operating temperature	-13 °F to +158 °F

Order Information

Key switch OPEN - CLOSE, surface type	part no. 700113
Key switch OPEN - CLOSE with half profile cylinder, surface type	part no. 700114
Key switch OPEN - CLOSE with half profile cylinder, flush mounting	part no. 700115

Large Surface Switch, Pulling Switch

Description

Large surface switches are recommended when the persons using the door either do not have empty hands and should be able to operate the switch with their elbow, or to facilitate the operating to handicapped persons. Especially for this purpose we furnish the non-contact large surface switch. By changing the colour it indicates if it has been actuated.

The **pulling switch** is mainly used in combination with the automatic closing when fork lift trucks frequently use the doors.

Contact: make contact (NO)

Dimensions Large Surface Switch

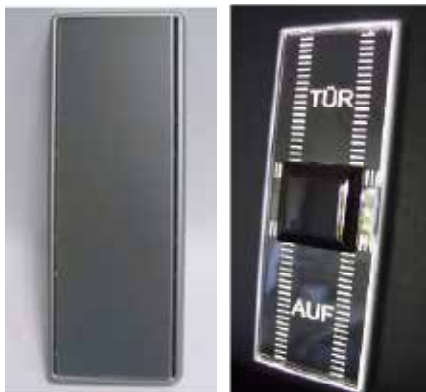

700194

700188

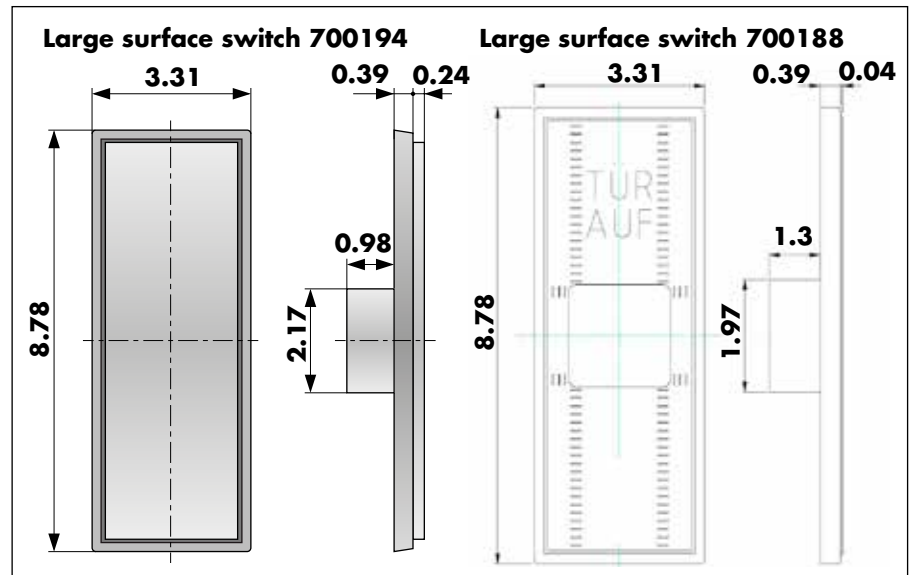

Dimensions Pulling Switch

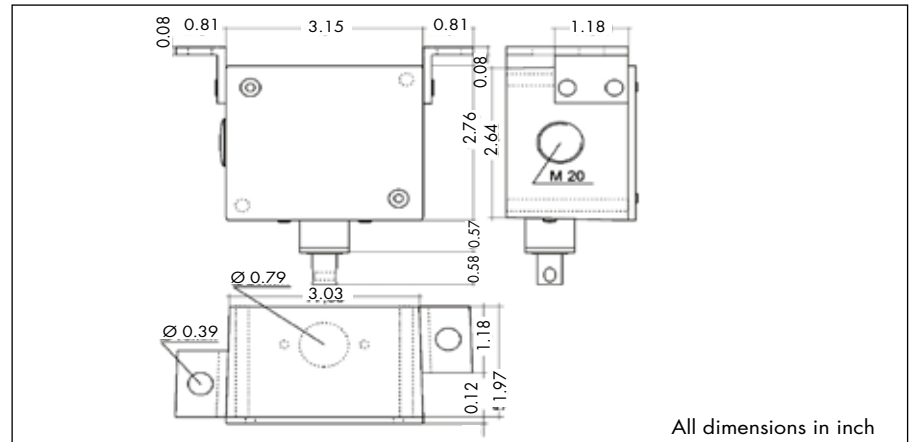

All dimensions in inch

Technical Data

IP rating large surface switch	IP 30
Operating temperature large surface switch	-4 °F to +122 °F
Operating temperature pulling switch	-22 °F to +122 °F
Power consumption/Voltage 700188	50 mA / 24 VDC
Detection range 700188 (adjustable)	1.97 - 59.06 inch
IP rating pulling switch	IP 65
Large surface switch, flush mounting, stainless steel appearance	part no. 700194
Large surface switch, flush mounting, non-contact	part no. 700188
Pulling switch (for alternating impulse OPEN-CLOSE)	part no. 700164

Order Information

Switches Especially for Fire Protection Doors

Description

Fire protection doors have to close automatically in case of alarm. The alarm can be triggered by a smoke detector or by a hand release switch. In case of the semi-automatic door operators DICTAMAT 560, 570 and 650 a push-to-lock key is required. For the fully automatic door operators the standard **hand release switch**, part no. 040005 or 040053 (see chapter Fire Door Control Solutions) is sufficient.

Every alarm requires afterwards a **RESET** command for the control system to resume normal operation.

For the **DICTAMAT 6000** a special hand switch with 2 make contacts (OPEN and RESET command at the same time) is necessary.

Contacts:

OPEN	2 x make contact (NO)	STOP	make contact (NO)
CLOSE	break contact (NC)		

Dimensions Push-to-lock Hand Switch

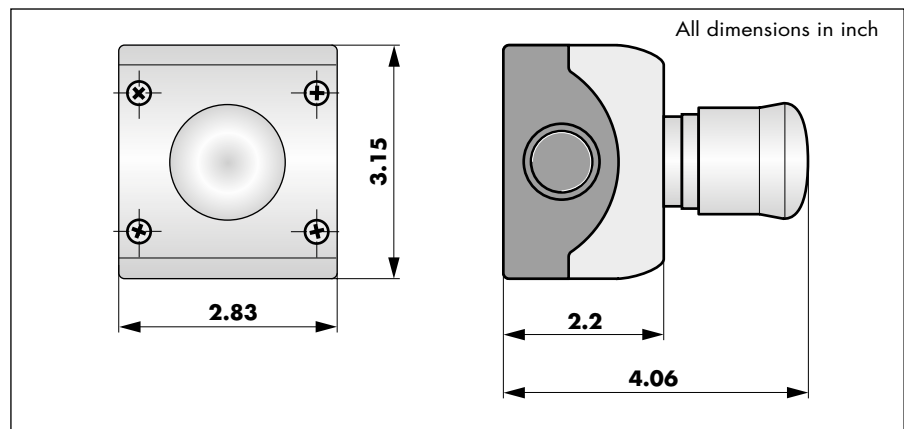

Dimensions RESET

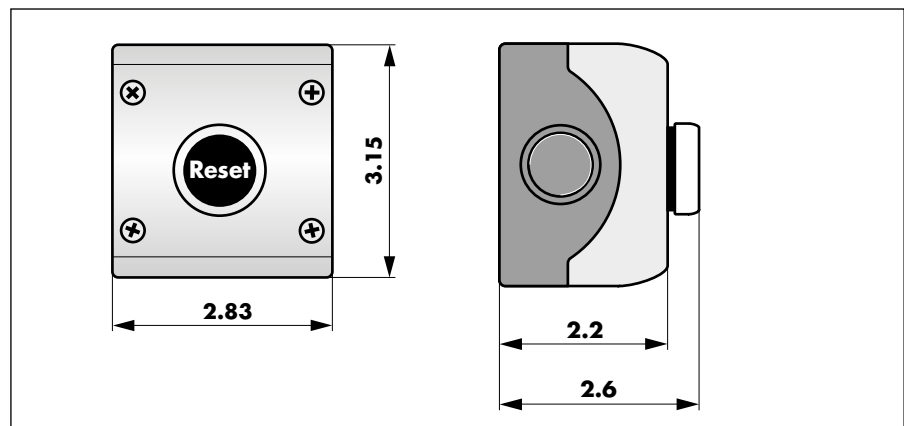

Technical Data

IP rating	IP 67
Operating temperature	-13 °F to +158 °F

Order Information

Push-to lock hand switch (break contact - NC)	part no. 700132
RESET switch (make contact - NO)	part no. 700112
Push button switch OPEN - CLOSE for DICTAMAT 6000*	part no. 780640
Push button switch OPEN-STOP-CLOSE for DICTAMAT 6000**	part no. 780641

* For dimensions see push button switch 700117, page 04.067.00

** For dimensions see push button switch 700147, page 04.067.00

Other Switches: Emergency-STOP, Limit Switch, Main Switch

Description

For large sliding doors an **Emergency-STOP switch** should be provided for safety reasons.

Limit switches are necessary for all door drives without integrated position control system.

In order to be able to completely cut off the power supply, a **main switch** should be installed directly in the power supply of the control system.

Dimensions Emergency-STOP Switch

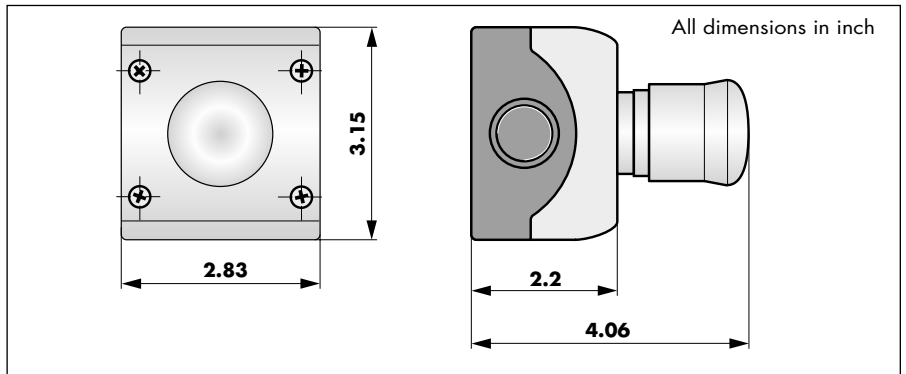

Dimensions Limit Switch

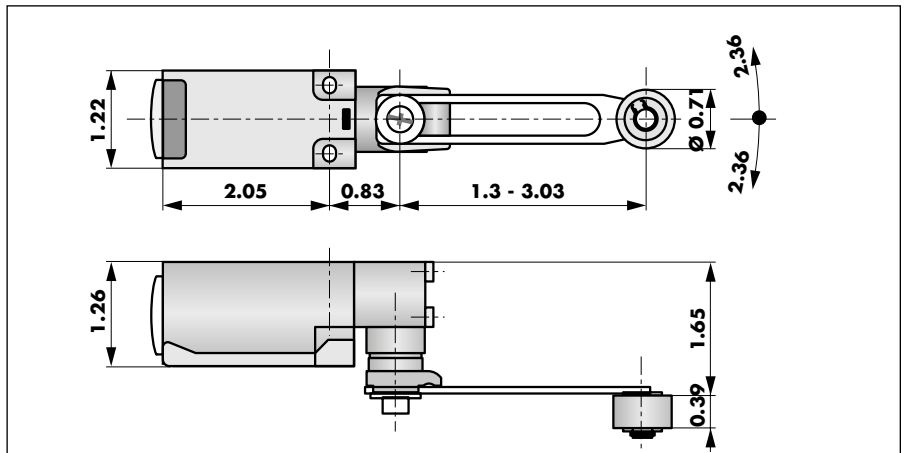

Dimensions Main Switch

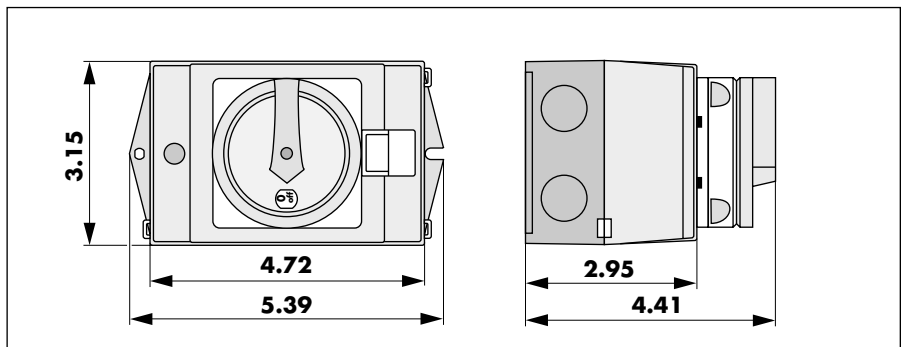

Technical Data

IP rating	Limit switch IP 65
Operating temperature	-13 °F to +158 °F

Order Information

Emergency-STOP switch (push-to-lock) (break contact - NC)	part no. 700198
Limit switch (break contact - NC)	part no. 700156
Lockable main switch (for padlock)	part no. 700179

Explosion-Proof Hand Switches

Description

DICTATOR furnishes special door operators for the use in hazardous areas - along with the required operating elements. The push button switches are available as simple, two and 3-keys switches: OPEN, CLOSE, STOP, RESET, hand release switch for fire protection doors.

Contact: All keys can be connected either as make or as break contact. Below are marked the contacts that have to be used together with the DICTATOR door drives. The STOP key has to be connected either as a make or a break contact, depending on the control system.

ATEX-certificate: PTB 01 ATEX 1105

Dimensions Push Button Switches

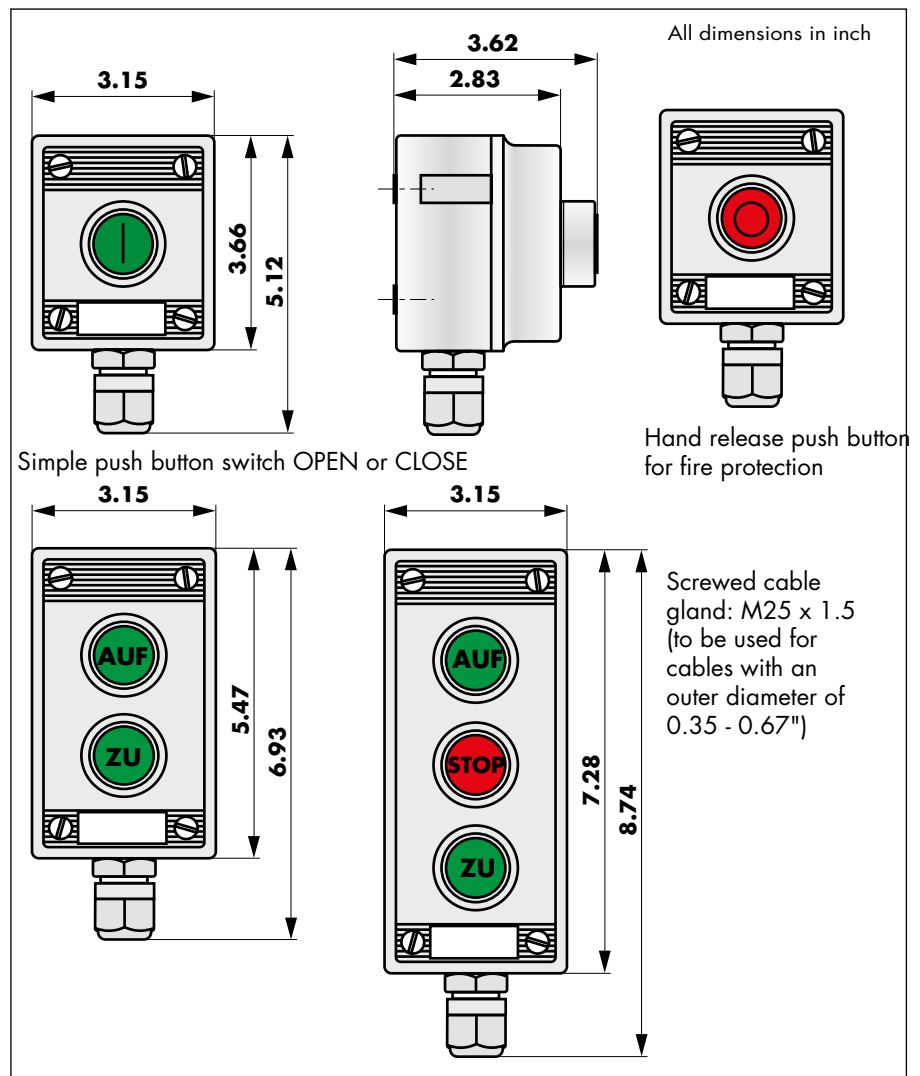

Technical Data

IP rating	Ex II 2 G EEx dem IIC T6 (zone 1 and 2), IP 66
Casing	glass fibre reinforced polyester resin

Order Information

Ex-proof push button OPEN or CLOSE (make contact, NO)	part no. 700219
Ex-proof push button OPEN - CLOSE (2 make contacts, NO)	part no. 700217
Ex-proof push button OPEN - STOP - CLOSE	part no. 700247
Ex-proof push button RESET (make contact, NO) (blue key)	part no. 700212
Ex-proof hand release push button (fire protection) (break contact, NC)	part no. 700232

Further Explosion-Proof Switches: Pull Switch

Description

The **pull switch** is mainly used in combination with the automatic closing when fork lift trucks frequently use the door.

Type of contact: The pull switch is provided with both a make and a break contact as all the other ex-proof switches. Normally the break contact is used.

ATEX-certificate: TÜV 03 ATEX 2043X

Dimensions

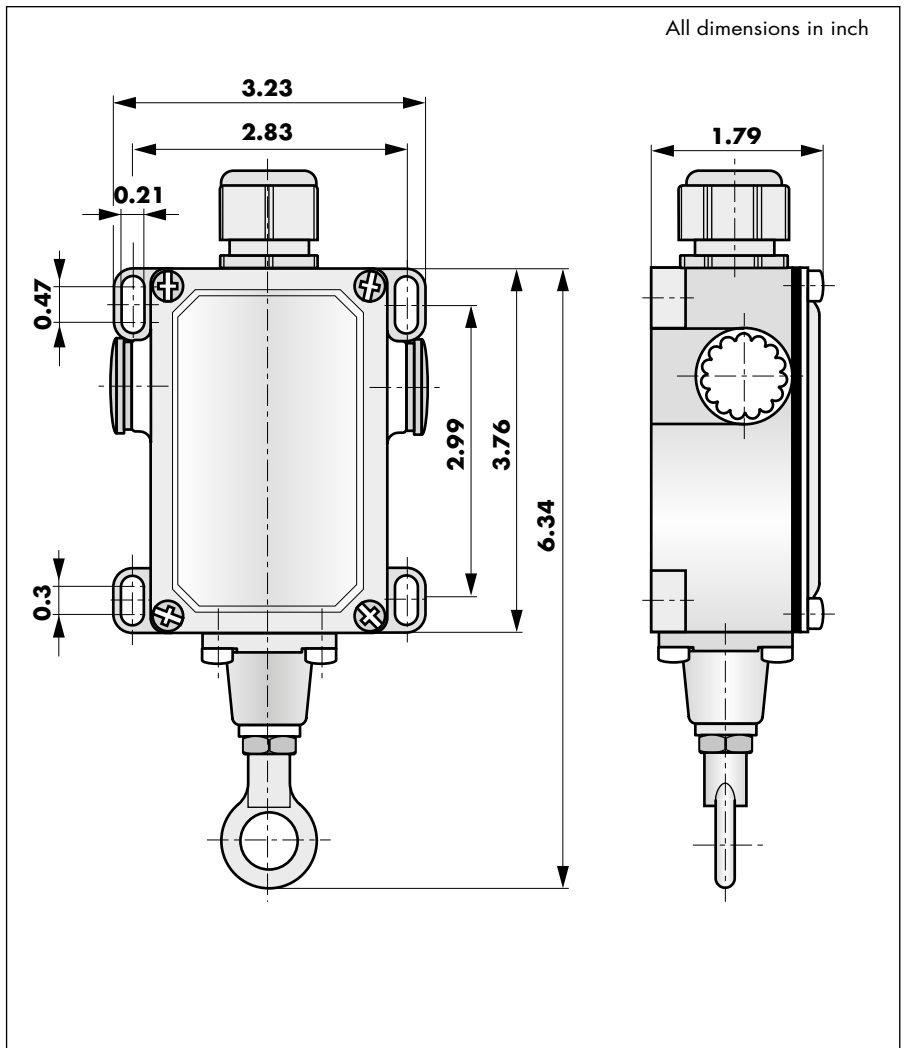

Technical Data

Ex-rating, IP rating	Ex II 2 G EEx d IIC T6, IP 66/67
Casing / Lid	aluminium diecasted / aluminium sheet metal
Operating temperature	-4 °F to +158 °F

Order Information

Ex-rated pull switch (make contact, NO)	part no. 700239
---	-----------------

Further Explosion-Proof Switches: Emergency-STOP Switch, Limit Switch

Description

For safety reasons an **Emergency-STOP switch** should be provided for large sliding doors.

Contact: The Emergency-STOP switch is furnished with both a make and a break contact as all the other ex-proof switches. Normally the break contact is used.

The explosion-proof door drives generally require ex-proof **limit switches** for the position control.

Dimensions Emergency-Stop Switch

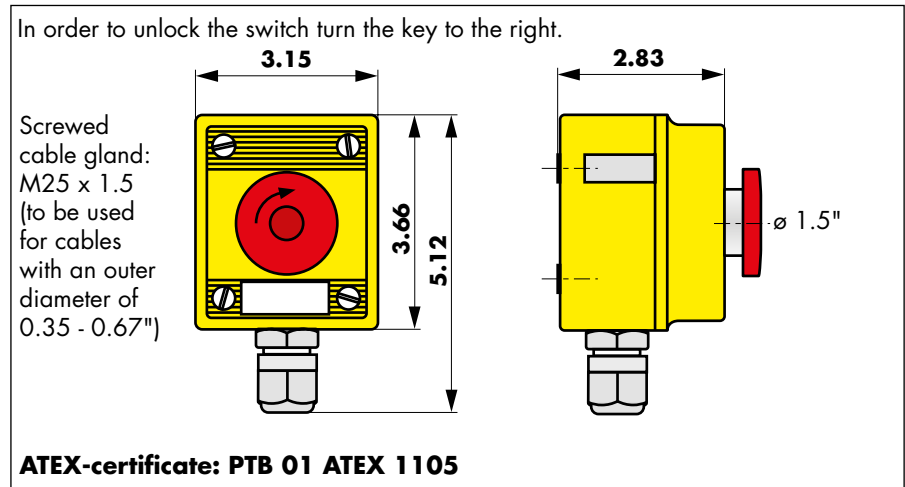

Dimensions Limit Switch

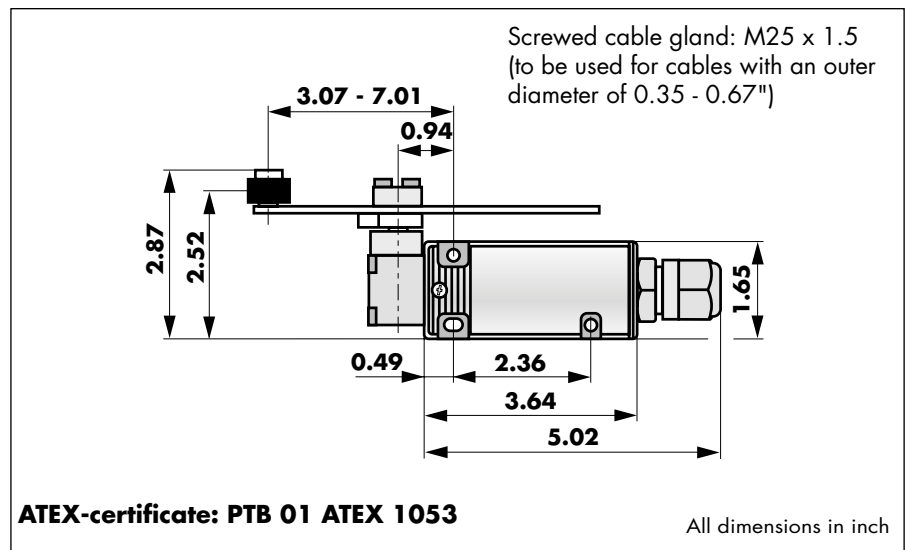

Technical Data

Protection rating Emergency-STOP	Ex II 2 G EEx dem IIC T6 (zone 1 and 2), IP 66
Protection rating limit switch	Ex II 2 G EEx ed IIC T6 (zone 1 and 2), IP 65
Casing	glass fiber reinforced polyester resin

Order Information

Ex-proof Emergency-STOP switch (push-to-lock switch) (NO, NC)	part no. 700254
Ex-proof limit switch (NO / NC)	part no. 700223

DICTATOR Door Operators

Examples of Customized Designs

DICTATOR offers a wide range of DICTAMAT door operators, from **semi-automatic operators** (opening by hand, controlled closing by the DICTAMAT operator) up to the **fully automatic door operator with microprocessor control system** (for hinged and sliding doors and also for fire protection doors).

But even this **comprehensive product range** provides not a suitable standard operator for all applications. Often doors, windows and multi-media facilities not only have to be moved, they must also conform to aesthetic requirements and architectural considerations.

Many years of experience enable DICTATOR to design and develop bespoke door operators for the most unusual applications and demanding specifications. Either by modifying a standard unit or by manufacturing a completely **bespoke unit** a suitable operator can be produced using our widely flexible manufacturing facilities.

On the following pages you will find some examples of our customized designs.



Technical Data

Door sizes	1.64 - 305 ft (largest door at the moment)
Moving elements	hinged, folding, sliding, telescopic doors, windows, wall/façade elements, multi-media facilities
Motors	direct current, three-phase current, explosion-proof
Control systems	simple electric control systems up to SPS-control systems with frequency converter, also with battery back-up
Components included	complete door operator with fixing accessories, control system (including installation, if necessary)



197, 262, 305 ft Fire Protection Telescopic Sliding Doors

The special design of fire protection telescopic sliding doors has proved to be beneficial on four occasions in Spain. The fire protection doors have been installed in **Madrid Airport** and in shopping centres of **Corte Inglés** and **Pryca**. The doors are opened in the morning and closed at night. By using these doors it is unnecessary to have fire walls that restrict access during the day. Clients and airport visitors can wander freely through malls and concourses without hindrance from fire walls.

305 ft Door in Santander, Corte Inglés



Customer Specification

The sliding fire protection doors open from the middle. Each side of the door consists of **up to six variable span wings**, each with a **width of up to 33 ft**. The whole **door system** extends from **rails on the ceiling**. On the floor there is only an approx. 1.18x1.18" wide guiding slot for one door wing. The door is opened in the morning and closed in the evening. It is operated by impulse with OPEN/STOP/CLOSE functions. As safety devices a contact edge is connected and a warning siren when the door closes. When the safety device is triggered, the door must **stop within 3.94"**. In the **event of fire** the door closes immediately (controlled via a central alarm). However even **in the event of alarm** the door must stop immediately after a signal from the **safety device**. After the safety device having been **released** the door must continue to **close** by itself (time is adjustable).

Solution

Each side of the door is moved by a **three-phase motor**. The force is transferred via a **tensioned chain**, guided in special fittings that prevent sagging. Both sides of the **variable span wings are synchronized** with each other. Both motors are managed by an **SPS control system with a frequency converter**. This enables adjusting the functions to correspond to individual customer requirements. Further adjustments which may be required later can without difficulty be realized by the SPS control system.

The **fire protection function** is guaranteed by a **battery back-up**. In two cases this was set up by the customer and in the other two DICTATOR supplied the battery back-up together with the control system.



Horizontal Sectional Door with Sharp Bend

The Hermès building in Tokio has a façade that is made of single, flexibly suspended glass blocks, that have been designed to give the impression that the whole building is moving like bamboo in the wind. This idea of architect Renzo Piano (Centre Pompidou/ Paris, Daimler City/Berlin) applied also to the **garage entrance door**. It is **made of the same glass blocks** and from the exterior cannot be distinguished as a door.

Horizontal Sectional Door Made of Glass Blocks in the Hermès Building in Tokio

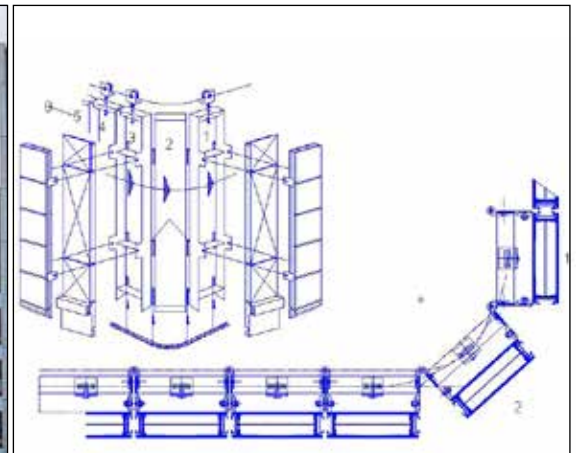

Customer Specification

The horizontal sectional door is made of **8 elements**, total weight about **4400 lbs**. These 8 elements have to **round a 90° bend within a distance of 11.81"**. Such a heavy door can only be operated with a chain, that has to be guided as well around this bend. As the object is very far away from production and the time to develop this special solution was very short, a very close cooperation with the manufacturer of the door was required. It was realized by exchanging CAD drawings.

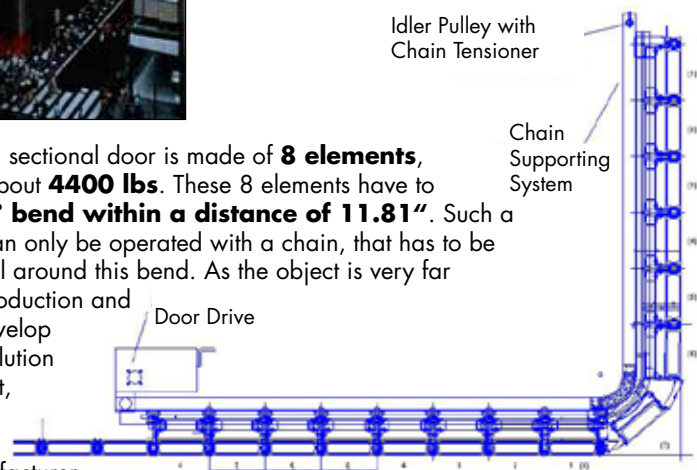

Solution

The 8 elements of the door are operated with a **three-phase current motor with frequency converter**. The **power transmission** is effected by a **chain**. The chain is guided in a special **aluminium rail with plastic lining**. In the bend the chain is guided over special plastic rollers. The **fixing bracket** to connect the chain to the door has a **flexible fixing** in order to compensate for any differences of distance. The elements of the doors are moved by **special hangers** (one hanger per element). DICTATOR supplied the door drive with the chain guide system and the hangers.



Further Examples of Customized Solutions

You will find more and more DICTATOR customized solutions in the most different sectors. Please ask for detailed information or the solution of your special application/problem.

Sliding Door Made of 6 Glass Elements in Dubai (weight per element approx. 2200 lbs)

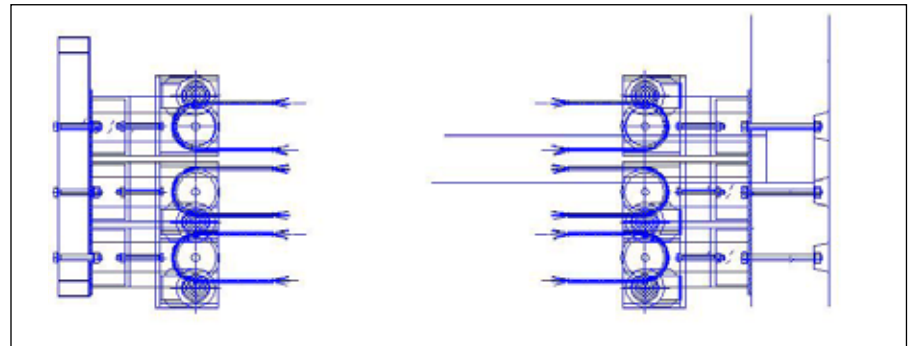

Multi-Media Wall in the Training Center of the AKV (Assurance Company) in Mainz/Germany



Technics, optics and acoustics become more and more important in training centers. Additionally these facilities have to be flexible. In the shown property (training hall of the AKV in Mainz) the company Haase & Co., Mainz/Germany installed a customized multi-media wall, which normally is concealed but can be used at the push of a button.

Automatic Hinged Doors operated by a logic control for 26 doors integrated in an automatic transport system with Automated Guided Vehicles in a pharmaceutical plant.

