

HLS-Catch Temperature Bolt

Safely Closed Fire Protection Doors - Without Gap

Perfectly functioning fire and smoke protection doors are an indispensable requirement for preventing and limiting damage. Especially with hinged doors, the great heat of a fire might cause the door to distort. This could produce a dangerous gap through which the fire could spread further, in spite of the fire protection door.

The **Hot-Locking-Safe** temperature bolt offers protection for life and material in a simple and unobtrusive way. The temperature bolt is installed in the frame or the door at those places where there is the highest danger of a gap occurring. Normally the bolt is retracted in the casing and locked there by the soldered strut. Only when the surrounding temperature rises to about 600 °C and the HLS bolting has reached about 65 °C the soldered strut melts and the spring in the back of the cylinder can push out the bolt. This fixes the door securely to the frame and the door leaf cannot distort.

IMPORTANT: The HLS-catch temperature bolt may only be installed in accordance with the respective door producer.



Technical Data

Material casing	zinc-plated steel
Material soldered strut	Hotmelt
Melting point	at a surrounding temperature of 600 °C
Spring force	approx. 11 N
Application area	hinged fire protection doors T30 and T60
Door types	timber and steel doors with timber or steel frames
Test	DIN EN 1634-1:2000

Dimensions TV2003-50

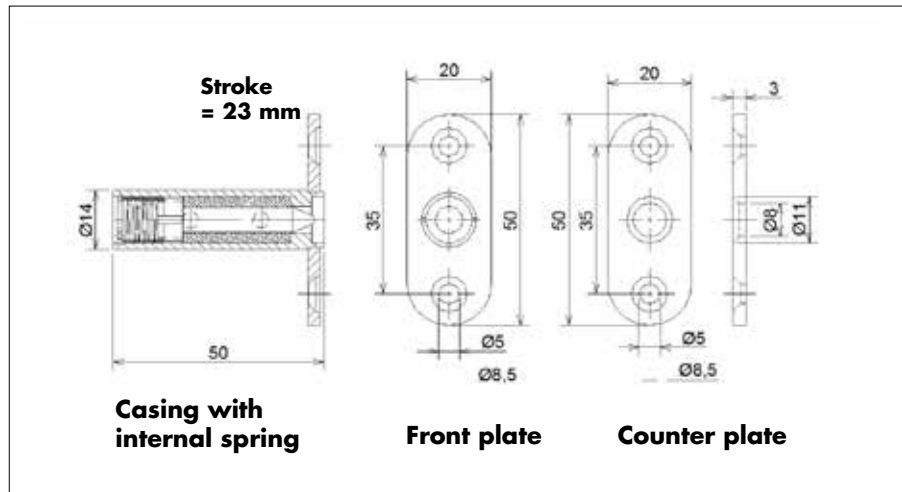

Installation Example

Usually the HLS-catch temperature bolt is installed in the frame. However, it is also possible to fit it into the door leaf. The number and the position have to be decided upon together with the door manufacturer.

It is very important that both HLS-catch and its counter plate are installed exactly opposite each other.

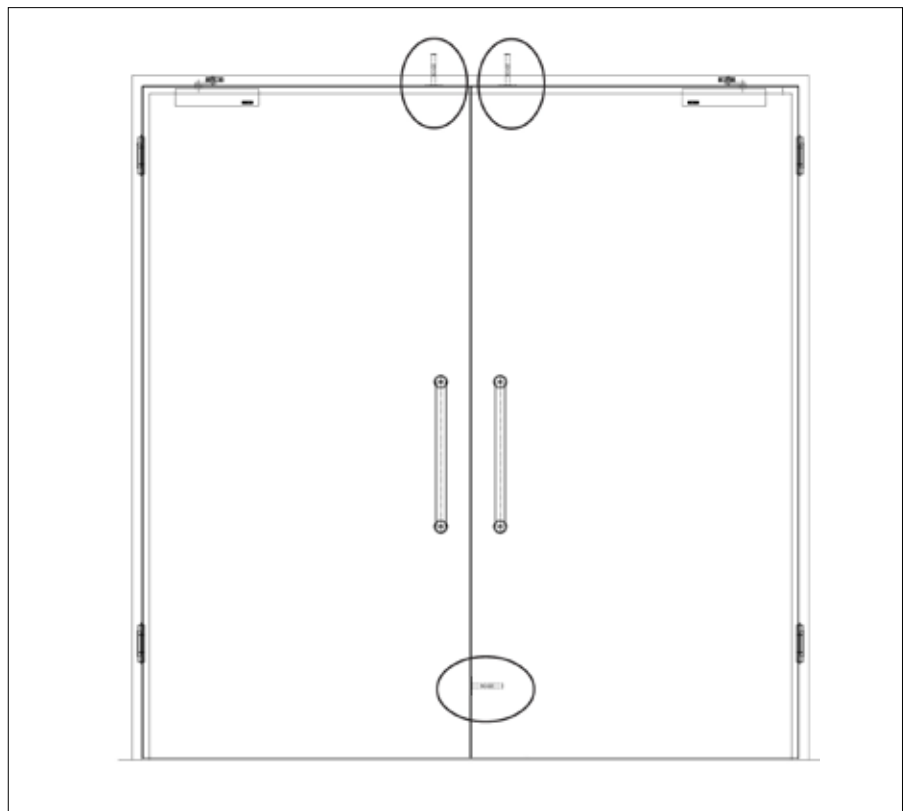

Order Information

HLS-catch TV2003-50, Hotmelt, 23 mm stroke

part no. 710715