

## Ex-Proof Electromagnet for the Exclusive Use in Hazardous Zones 2 and 22

Hazardous areas are divided into different zones. As zones 2 (gas) or 22 (dust) are defined areas where during normal operation no dangerously hazardous atmosphere occurs or when only during a short period. The demands on devices used in these zones are minor to those applying to the ex-proof DICTATOR electromagnets, series EM GD Ex m.

Therefore, DICTATOR provides for the use in hazardous areas of the zones 2 and 22 an **economic** alternative, the EM GD 70 R39I Ex2 ex-proof magnet.

The following three features distinguish it from the normal EM GD 70 R39I:

- connecting terminal for the prescribed equipotential bonding,
- larger base plate,
- special label for hazardous areas.

By default the EM GD 70 R39I Ex2 is equipped with diodes to suppress the induced current on opening (spark extinction diodes) and polarity protection.

The electromagnets have been tested according to EN 1155 and are among others included in the following approvals: Z-6.5-1903, Z-6.5-1707.



### Technical Data

Electromagnet	EM GD 70 R39I Ex2
Voltage	24 VDC $\pm$ 15 %
Power consumption ( $\pm$ 15 %)	71 mA (1.7 W)
Force / Remanence	1450 N / 0 N
Ignition protection type	<div style="display: flex; align-items: center;"> <span style="font-size: 1.2em; margin-right: 5px;">Ex</span> <span>II 3G Ex nC IIC T6 Gc X</span> </div> <div style="display: flex; align-items: center;"> <span style="font-size: 1.2em; margin-right: 5px;">Ex</span> <span>II 3D Ex nC IIIC T85°C Dc X</span> </div>
Protection / Duty cycle	IP 65 / 100 %
Operating temperature	-20 to +60 °C
Connection	connector box GDML 2011 GE 1 G, PG 11
Finish	magnet and base plate zinc-plated

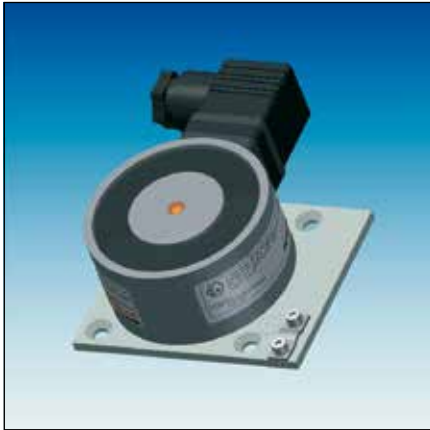

**Dimensions, Application, Accessories**

The EM GD 70 R39 I Ex2 electromagnet may exclusively be used in hazardous areas of the zones 2 and 22.

More conditions for the use in the zones 2 and 22:

- The magnet must be protected against mechanical impact.
- A protective earth connection is mandatory.
- A fuse has to be connected upstream to the magnet.
- All regulations for hazardous areas have to be observed.

**Dimensions**

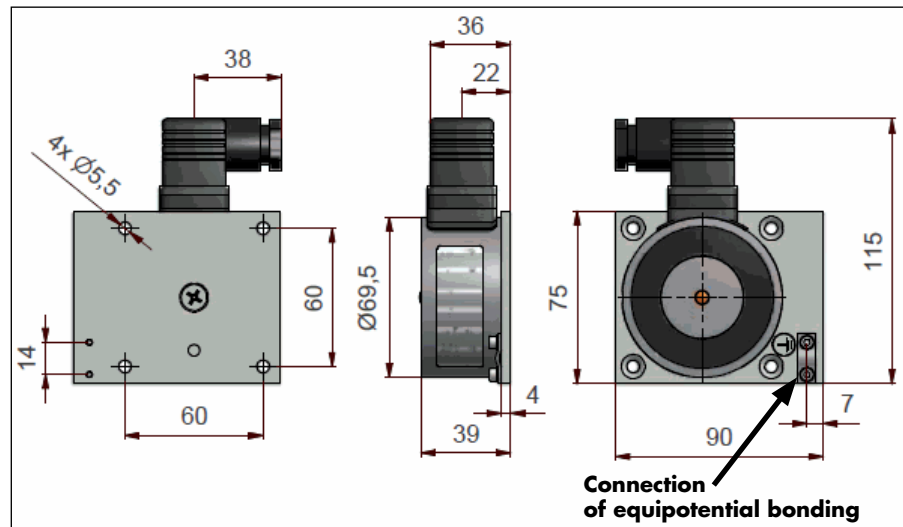

**Electrical Connection**

**Connection polarity on the plug:**

- Screw terminal 1 (+)
- Screw terminal 2 (-)

**Fuse, Fuse Carrier**

To protect the magnet from a possible short circuit, a fuse T 200 mA with a minimum breaking capacity of 1500 A has to be connected upstream to the magnet.

The fuse carrier with the fuse is placed directly into the feeding line to the magnet. There are available two different types of fuse carriers.

- Fuse carrier for soldering directly into the feeding line, with bayonet catch  
Dimensions of the fuse carrier: L = 43.2 mm, ø = 14.2 mm  
Suitable for cables with a cross section up to max. 4 mm
- Fuse carrier for mounting on top hat rails, with pivoting retaining bracket

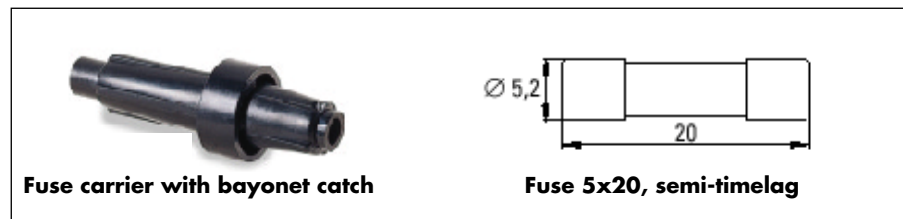
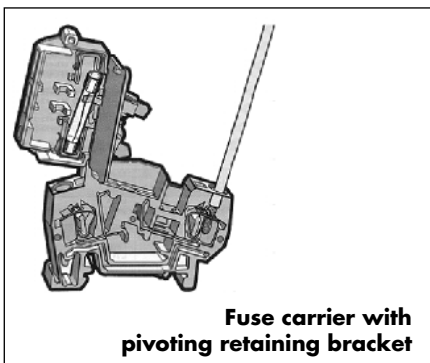

**Order Information**

EM GD 70 R39 I Ex2 electromagnet (zones 2 and 22), 1450 N	part no. 040190
Fuse 5 x 20, semi-timelag, 200 mA	part no. 040586
Fuse carrier with bayonet catch	part no. 040587
Fuse carrier with pivoting retaining bracket	part no. 040588