

## RZ-24-05 Central Unit, the "Design Solution" for Hold-Open Systems

The RZ-24-05 central unit is ideal for all hold-open systems in which particular emphasis is placed on design or which have to meet special aesthetic and architectural requirements. The RZ-24-05 is so small that it fits easily into a standard flush-mounted box. The hand switch integrated in the RZ-24-05 central fits in most switch ranges.

Especially for hold-open systems that are subject to high loads, such as in schools, kindergartens, hospitals or other public buildings, separate (not integrated in overhead door closers) robust electromagnets are the prerequisite for a long service life of the hold-open system. Combined with the small control unit, which fits perfectly and inconspicuously into the existing electrical installation, DICTATOR thus offers a sustainable design solution that prevents high repair and maintenance costs.

Despite its small dimensions, the RZ-24-05 has all the essential functions of a central unit for hold-open systems. And it provides the very high output of 500 mA for connected consumers.



### Technical Data

Supply voltage	85 - 264 VAC
Power consumption	about 14 W, own consumption about 40 mA
Secondary output voltage	24 VDC $\pm$ 10 %
Secondary total load	permanently 0.5 A (supply of fire detectors, electromagnets and other consumers)
Operating temperature	0 °C to +40 °C
IP rating	IP 30



## RZ-24-05 Central Unit - Functions and Installation

The RZ-24-05 has been tested and approved by the Deutsches Institut für Bautechnik (German Institute for Building Engineering). It also meets the demands of the EN 14637 on hold-open systems.

The standard version of the RZ-24-05 is designed for installation in a commercially available flush-mounted box with a diameter of 60 mm. Normally, the frame of the switch system used in the object is used. However, a frame is also available if required.

### Standard Version

- **Manual release** of the hold-open system by the hand release switch integrated in the RZ-24-05.
- **Tripping** the hold-open system by connected **fire detectors**.
- **Tripping** the hold-open system by a **fire alarm central** (requires a potential-free contact).
- **RESET** of the complete hold-open system via the keypad of the RZ-24-05:  
First reset the fire detectors by the hand release switch and then the RZ-24-05 central by its integrated RESET switch.
- **Automatic RESET after a power cut or actuating the hand switch** (if required, adjustable in the central unit by means of a DIP switch)
- **Integrated excess-current protection**: If too many consumers are connected, the power supply automatically cuts off.
- **Status indications** for normal operation, alarm and various fault conditions on the keypad

### Installation Instructions

Normally, the RZ-24-05 is installed in a standard flush-mounted box (not included in the delivery, see figure below).

A model provided by the customer can be used as a frame for the circuit board with hand switch (IMPORTANT: switch cut-out 55 x 55 mm, without rounded corners!).



### Indication and Operating Elements of the RZ-24-05

#### Keys

- Integrated hand release key (1)
- Integrated RESET key (2)

#### Status indications

3 different LEDs in the cover (3) (explanation from top to bottom):

- LED "Release": lights up red in case of alarm
- LED "Ready": lights up green when the detector loop is ready for operation
- LED "Error": by permanent lighting or flashing with different frequencies different errors are indicated!





### RZ-24-05 - Connection

When carrying out the electrical connection work, please note that due to the small size of the board and terminals, a special release tool (part no. 040565) must be used for the miniature terminals to prevent damage. This release tool can also be obtained from DICTATOR.

For connection, the wires are simply plugged into the corresponding terminals.

**Important note:** A 3.9 k $\Omega$  resistor is already included with the RZ-24-05. This is required when connecting the fire detectors RM 4000/WM 4000.

### Inputs/Outputs

The RZ-24-04 has 14 connection terminals for cables with a maximum of 0.75 mm<sup>2</sup>.

#### Inputs

- Mains connection
- External reset or central closing

#### Outputs

- Supply of the fire alarm loop with fire and/or heat detectors (with terminating resistor 3.9 k $\Omega$ )
- Supply 24 VDC for the electromagnets
- Output +/- for warning signal

### Overview Connection Terminals

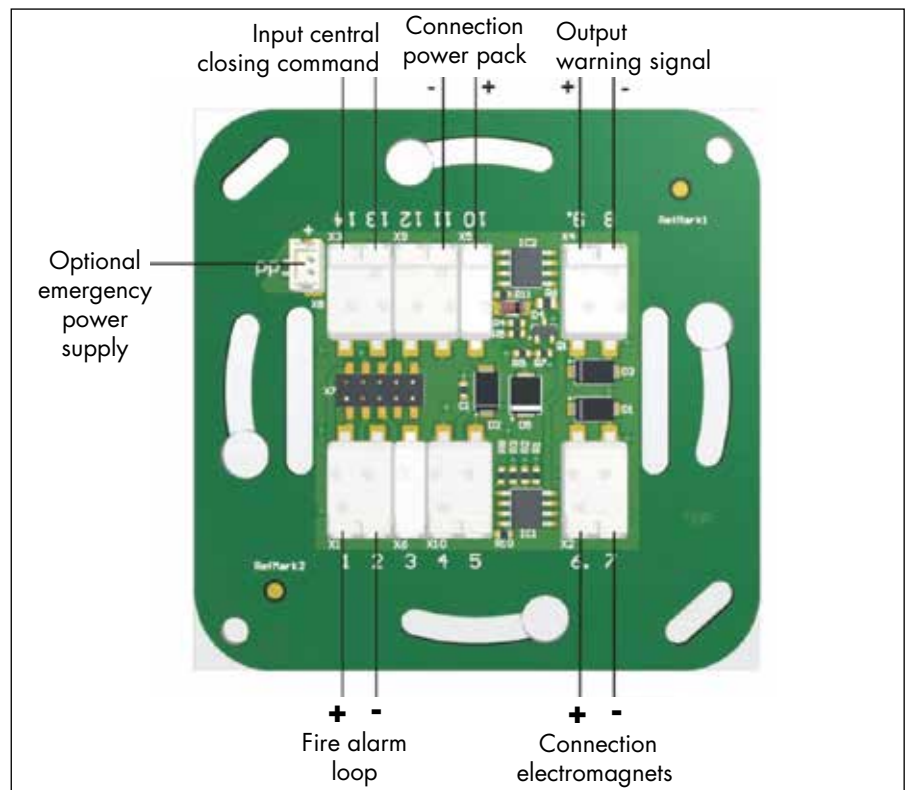



### Central RZ-24-05 - Accessories, Order information

If no cover frames of the switch system used by the customer are used when installing the RZ-24-05, the cover frame can also be supplied by DICTATOR.

In addition to the normal cover frame, also a cover frame with transparent flap is available. According to the type approval of the DIBt it is permissible to protect a hand switch against misuse by a suitable transparent cover (e.g. flap). A further advantage is that accidental operation of the manual release button is prevented in the case of heavy public traffic.

### Cover frame with transparent cover



### Emergency Power Supply

If there are occasional short interruptions in the power supply where the hold-open system is used, an additional emergency power supply can be used.

In this case please contact us. It is important that you tell us the exact number of connected consumers and their power consumption.

### Order Information

RZ-24-05 UP central unit, 0.5 A, for switch systems (surface or flush-mounted)	part no. 040563
Cover frame for RZ-24-05 for installation in flush boxes	part no. 040566
Cover frame, polar white, with transparent cover for RZ-24-05 for installation in flush boxes	part no. 040567
Tool for removing wires from the miniature terminals	part no. 040565