

Pull Type Gas Springs

DICTATOR pull type gas springs are the answer to your problems if you are unable to use normal push type gas springs due to a lack of space. They work in the opposite way to push type gas springs as the **gas pressure inside the cylinder causes the piston rod to retract inwards**.

Depending on how they are installed, pull type gas springs either open or close flaps, windows and hatchways. **In the example opposite**, the pull type gas spring always pulls the fork lift truck shaft into a vertical position.

In the same way as with push type gas springs, we manufacture your pull type gas spring according to your **individual application requirements** - as a **single unit**, in small or large batches.

Along with their different function pull type gas springs differ from normal push type gas springs by their longer length and larger cylinder diameter, although they have the same piston rod diameter.

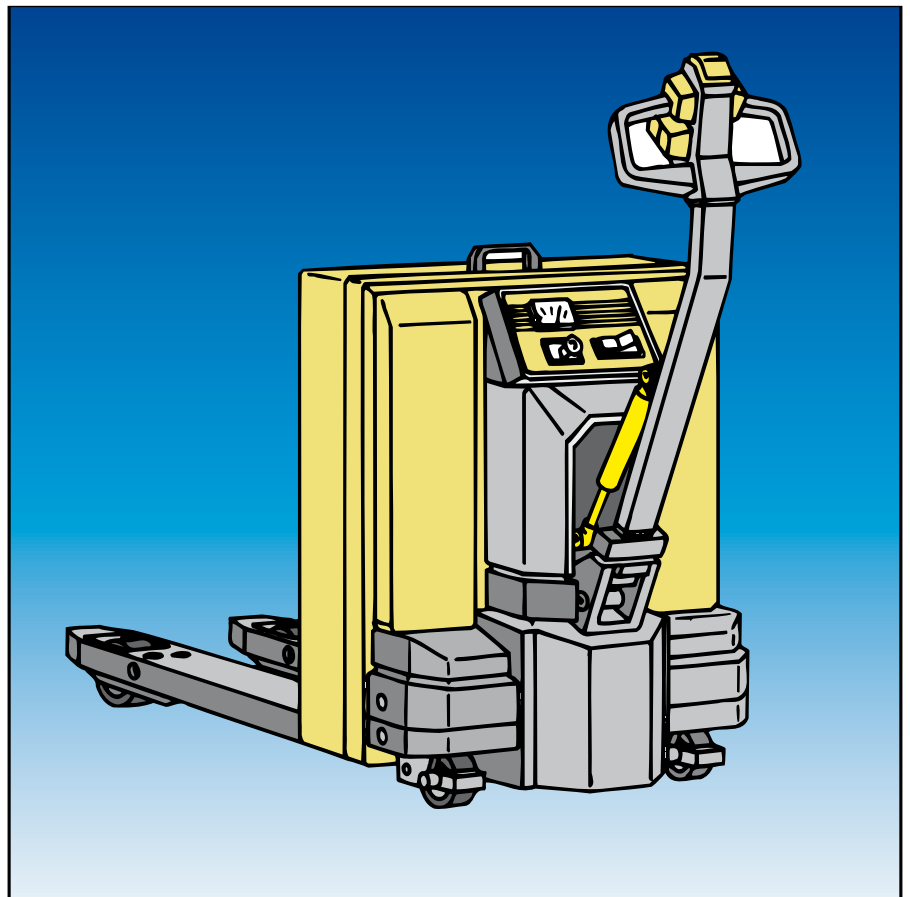

Technical Data

Piston rod diameter	6, 10, 28 mm
Cylinder diameter	19, 28, 40 mm
Pulling force	30 N - 5000 N
Stroke length	10 mm - 600 mm
Operating temperature	-10 °C (with special oil -30 °C) to +80 °C
Change in pressure	0.37 % per 1 °C (first filling at approx. 18° - 20 °C)
Gas	nitrogen (N), (non-flammable)
Maximum number of strokes	6 strokes per minute

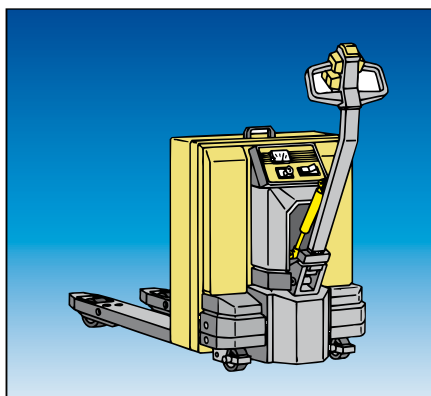

Summary of Pull Type Gas Springs

DICTATOR pull type gas springs are usually manufactured according to your individual requirements. The following table gives you a short summary of pull type gas springs available.

Information concerning possible additional options for pull type gas springs can be found at the bottom of this page. Detailed data concerning each individual diameter range, which will help you when selecting your gas spring, can be found on the following pages. Or let us advise you!

Technical Data

Ø Piston rod	6	10	10	28
Ø Cylinder	19	28	40	40
Min. stroke S (mm)	30	20	10	50
Max. stroke S (mm)	300	600	590	700
Damping	0	0	0	0
Min. force	30 N	150 N	200 N	500 N
Max. force	330 N	1200 N	2000 N	5000 N
Comp. L (GZ-GZ) *	L ext.- S (stroke)	L ext.- S	L ext.- S	L ext.- S
Ext. L (GZ-GZ) *	2 x S + 100	2 x S + 100	2 x S + 150	2.5 x S + 125
End fittings	GZ, A, G WG, GK	GZ, A, G WG, GK	GZ, A, G WG, GK	GZ, A, G WG, GK
Oil chamber (4) *	L + 20	L + 20	L + 20	no
Valve (5)	standard	standard	standard	standard
Protective tube (6) *	L + 5	L + 5	L + 5	L + 5

* All dimensions in mm. S = stroke, L = length, comp. = compressed, ext = extended
Example: 10-28 range; stroke 50; extended L = 2 x 50 + 100 = 200 mm]

Progression: Normally pull type gas springs have a slightly lower progression than the push type gas springs. By default it is approx. 20 %. If in your case the progression should be an important determining factor, please contact our technical department.

Additional Options

In pull type gas springs the piston rod should ideally point upwards in a vertical position. If this is not possible, please order your gas spring with an oil chamber (ATTENTION: observe the maximum force for oil chambers!). This ensures the seal is always covered by oil and does not become porous quickly. The **oil chamber** has **code no. 4**. (The total length increases by 20 or 30 mm.) (Please see page 06.010.00).

If your gas spring is going to be exposed to dirt, paint or other such hazards, and if there is danger of mechanical damage, please order a protective tube with your gas spring. The protective tube slides over the cylinder and piston rod and prevents damages. The **protective tube** has **code no. 6**. (The total length increases by 5 mm). (Please also see page 06.011.00).

Special Solutions

There are also available special models of the 10-28 series pull type gas springs, when they have to meet particularly high requirements regarding the service life, when they require damping when the piston rod is extending and/or entering or when it is not possible to mount them with the piston rod pointing up. These pull type gas springs are longer than the normal pull type ones (stroke x 3 + 65 mm). Please ask us, if you require such gas springs.

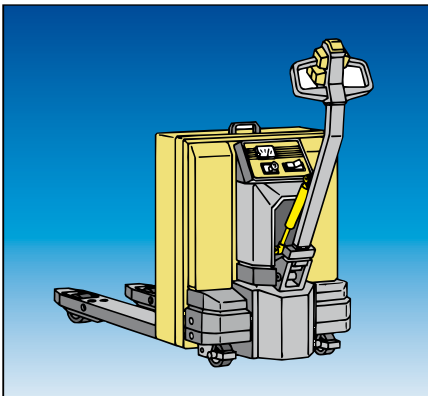

Z 6-19 Pull Type Gas Springs Force 30 N - 330 N

The smallest pull type gas springs are produced with a 6 mm piston rod diameter and 19 mm cylinder diameter. Please be aware that in contrast to push type gas springs, pull type gas springs should generally be installed with the piston rod pointing upwards. Z 6-19 pull type gas springs are **supplied with a valve** on the piston rod **as standard**.

With Z 6-19 pull type gas springs the eyelet is screwed onto the cylinder. End fittings from the 6-15 range are generally used. (Please see end fittings beginning on page 06.061.00).

End Fittings

On piston rod

On cylinder

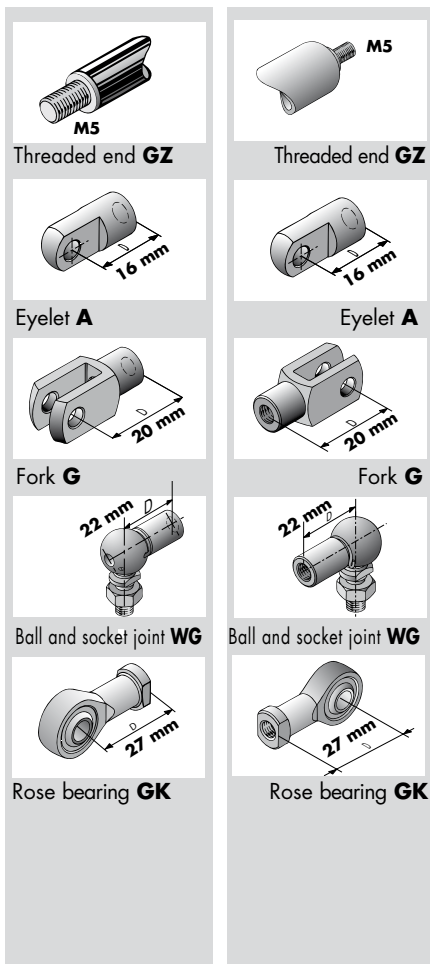

Exact dimensioned drawings for the above end fittings can be found on pages 06.061.00 - 06.064.00.

Types of damping for Z 6-19 range

0 = without damping

Determining Your Z 6-19 Pull Type Gas Spring

With help of the following table you can easily find the correct gas spring if you already know the necessary stroke and end fittings.

If you require a pull type gas spring not only with threaded ends, but also, for example, an eyelet on the piston rod or both ends, then simply add the measurement D given in the drawings of the end fittings to the extended length to achieve the total length. The same applies for additional options.

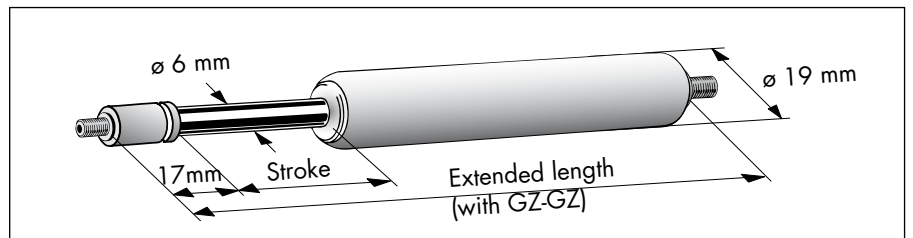

	Type Z	See page
1. Piston rod diameter:	<input type="text" value="6 mm"/>	06.082.00
2. Cylinder diameter:	<input type="text" value="19 mm"/>	06.082.00
3. Stroke (30 - 300 mm):	<input type="text"/>	06.082.00
4. Type of damping:	<input type="text" value="0"/>	06.005.00 06.083.00
5. Force (30 - 330 N):	<input type="text"/>	06.083.00
6. Compressed length (= extended length - stroke):	<input type="text"/>	06.084.00
7. Extended length (total length): (min. 2 x stroke + 100 mm + measurement D of end fittings + measurements of additional options)	<input type="text"/>	06.084.00
8. Piston rod end fitting (see drawing for symbol):	<input type="text"/>	06.061.00
9. Cylinder end fitting (see drawing for symbol):	<input type="text"/>	06.061.00
10. Additional options:	<input type="checkbox"/> Oil chamber (4) (total length + 20 mm) <input type="checkbox"/> Protective tube (6) (total length + 5 mm)	06.010.00 06.011.00

Additional details:

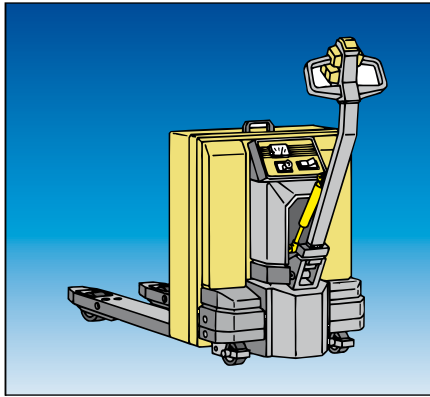

Z 10-28 Pull Type Gas Springs Force 150 N - 1200 N

Most pull type gas springs are manufactured with a 10 mm piston rod diameter and 28 mm cylinder diameter. Please be aware that in contrast to push type gas springs, pull type gas springs should generally be installed with the piston rod pointing upwards.

All Z 10-28 pull type gas springs are equipped as **standard with a valve** on the piston rod.

On demand, a longer version of the Z 10-28 pull type gas springs is available which is suitable for high service performances, differing mounting positions and damping types.

End Fittings

On piston rod

On cylinder

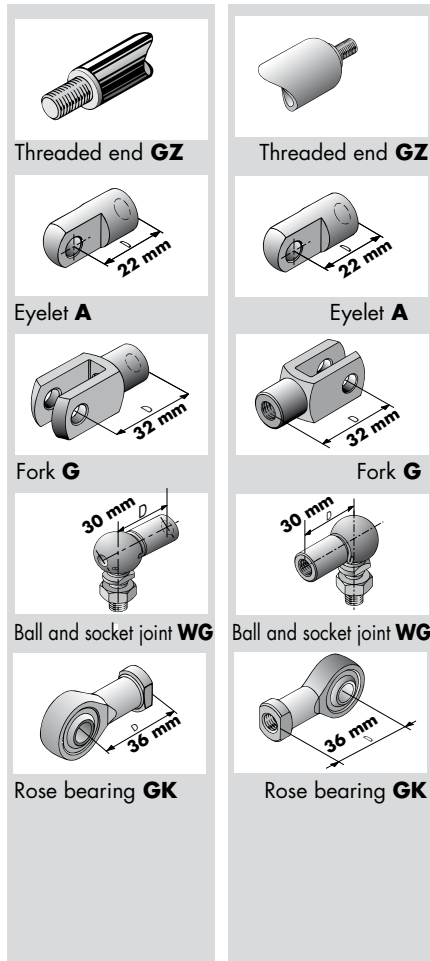

Exact dimensioned drawings for the above end fittings can be found on pages 06.061.00 - 06.064.00.

Types of damping for 10-28 range

0 = without damping

Determining Your Z 10-28 Pull Type Gas Spring

With help of the following table you can easily find the correct pull type gas spring if you already know the necessary stroke and end fittings.

If you require a pull type gas spring not only with threaded ends, but also, for example, an eyelet on the piston rod or both ends, then simply add the measurement D given in the drawings of the end fittings to the extended length to achieve the total length. The same applies for additional options.

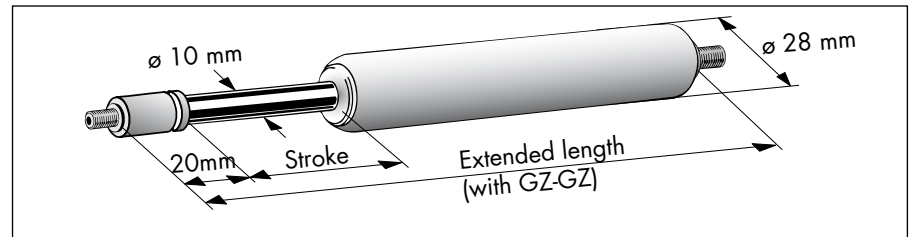

	Type Z	See page
1. Piston rod diameter:	<input type="text" value="10 mm"/>	06.082.00
2. Cylinder diameter:	<input type="text" value="28 mm"/>	06.082.00
3. Stroke (20 - 600 mm):	<input type="text"/>	06.082.00
4. Type of damping:	<input type="text" value="0"/>	06.005.00 06.083.00
5. Force (150 - 1200 N): (maximum force with oil chamber: 600 N)	<input type="text"/>	06.083.00
6. Compressed length (= extended length - stroke):	<input type="text"/>	06.084.00
7. Extended length (total length): (min. 2 x stroke + 100 mm + measurement D of end fittings + measurements of additional options)	<input type="text"/>	06.084.00
8. Piston rod end fitting (see drawing for symbol):	<input type="text"/>	06.061.00
9. Cylinder end fitting (see drawing for symbol):	<input type="text"/>	06.061.00
10. Additional options:	<input type="checkbox"/> Oil chamber (4) (total length + 20 mm)	06.010.00
	<input type="checkbox"/> Protective tube (6) (total length + 5 mm)	06.011.00

Additional details:

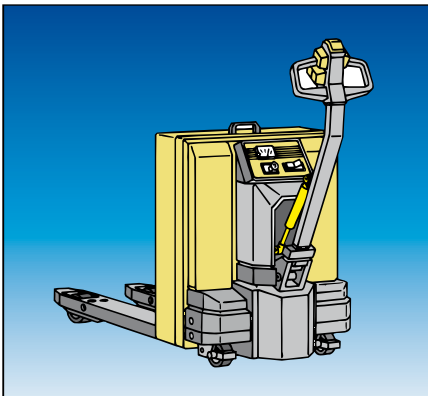

Z 10-40 Pull Type Gas Springs Force 200 N - 2000 N

For forces from 200 N - 2000 N we supply pull type gas springs with a piston rod diameter of 10 mm and cylinder diameter of 40 mm. Please be aware that in contrast to push type gas springs, pull type gas springs should generally be installed with the piston rod pointing upwards.

Z 10-40 pull type gas springs are supplied with a valve on the piston rod as standard. A thread-adaptor is attached to the piston rod in the Z 10-40 range. End fittings from the 20-40 range are generally attached to this thread on the piston rod as well as on the cylinder.

End Fittings

On piston rod

On cylinder

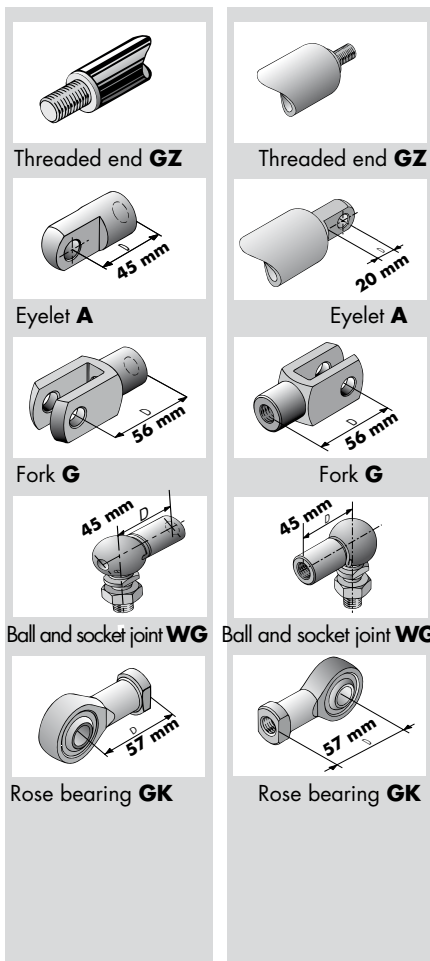

Exact dimensioned drawings for the above end fittings can be found on pages 06.061.00 - 06.064.00.

Types of damping for range Z 10-40

0 = without damping

Determining Your Z 10-40 Pull Type Gas Spring

With help of the following table you can easily find the correct pull type gas spring if you already know the necessary stroke and end fittings.

If you require a pull type gas spring not only with threaded ends, but also, for example, an eyelet on the piston rod or both ends, then simply add the measurement D given in the drawings of the end fittings to the extended length to achieve the total length. The same applies for additional options.

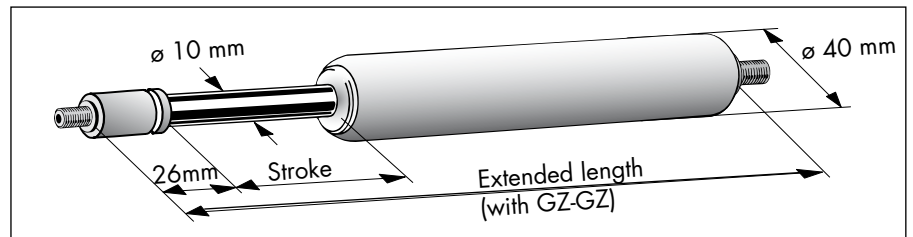

	Type Z	See page
1. Piston rod diameter:	<input type="text" value="10 mm"/>	06.082.00
2. Cylinder diameter:	<input type="text" value="40 mm"/>	06.082.00
3. Stroke (10 - 590 mm):	<input type="text"/>	06.082.00
4. Type of damping:	<input type="text" value="0"/>	06.005.00 06.083.00
5. Force (200 - 2000 N):	<input type="text"/>	06.083.00
6. Compressed length (= extended length - stroke):	<input type="text"/>	06.084.00
7. Extended length (total length): (min. 2 x stroke + 150 mm + measurement D of end fittings + measurements of additional options)	<input type="text"/>	06.084.00
8. Piston rod end fitting (see drawing for symbol):	<input type="text"/>	06.061.00
9. Cylinder end fitting (see drawing for symbol):	<input type="text"/>	06.061.00
10. Additional options:	<input type="checkbox"/> Oil chamber* (4) (total length + 20 mm) <input type="checkbox"/> Protective tube (6) (total length + 5 mm)	06.010.00 06.011.00

* maximum force with oil chamber: 1500 N

Additional details:

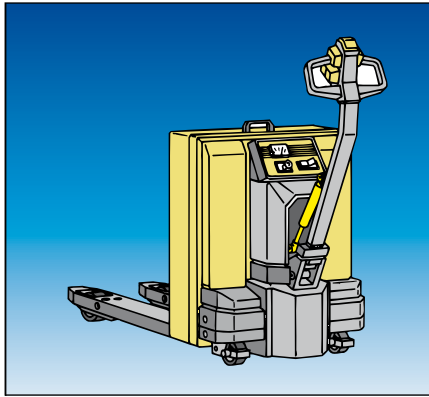

Z 28-40 Pull Type Gas Springs Force 500 N - 5000 N

The highest pulling forces can be reached with Z 28-40 gas springs with a 28 mm piston rod diameter and 40 mm cylinder diameter. Please be aware that in contrast to push type gas springs, pull type gas springs should generally be installed with the piston rod pointing upwards.

Z 28-40 pull type gas springs are supplied with a valve on the piston rod as standard.

Z 28-40 pull type gas springs have an M14x1.5 thread on both ends. End fittings from the 20-40 range are generally used on the piston rod as well as on the cylinder.

End Fittings

On piston rod

On cylinder

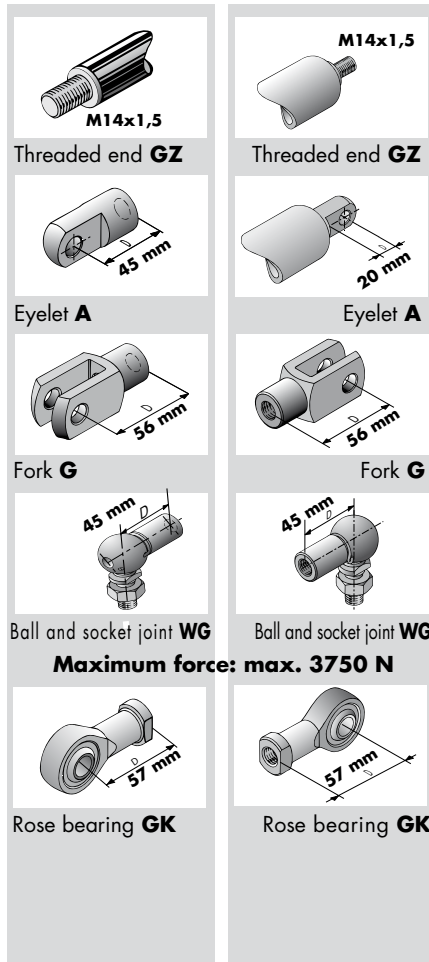

Exact dimensioned drawings for the above end fittings can be found on pages 06.061.00 - 06.064.00.

Types of damping for Z 28-40 range

0 = without damping

Determining Your Z 28-40 Pull Type Gas Spring

With help of the following table you can easily find the correct pull type gas spring if you already know the necessary stroke and end fittings.

If you require a pull type gas spring not only with threaded ends, but also, for example, an eyelet on the piston rod or both ends, then simply add the measurement D given in the drawings of the end fittings to the extended length to achieve the total length. The same applies for additional options.

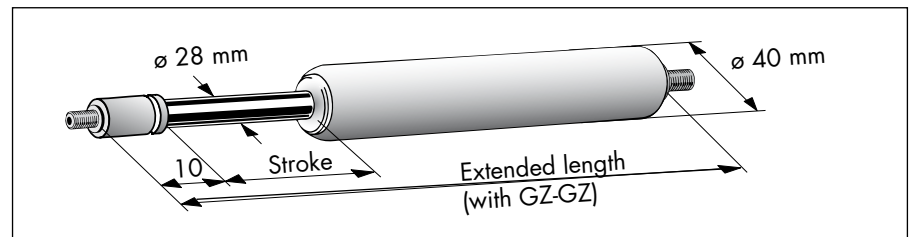

	Type Z	See page
1. Piston rod diameter:	<input type="text" value="28 mm"/>	06.082.00
2. Cylinder diameter:	<input type="text" value="40 mm"/>	06.082.00
3. Stroke (50 - 700 mm):	<input type="text"/>	06.082.00
4. Type of damping:	<input type="text" value="0"/>	06.005.00 06.083.00
5. Force (500 - 5000 N):	<input type="text"/>	06.083.00
6. Compressed length (= extended length - stroke):	<input type="text"/>	06.084.00
7. Extended length (total length): (min. 2,5 x stroke + 125 mm + measurement D of end fittings + measurements of additional options)	<input type="text"/>	06.084.00
8. Piston rod end fitting (see drawing for symbol):	<input type="text"/>	06.061.00
9. Cylinder end fitting (see drawing for symbol):	<input type="text"/>	06.061.00
10. Additional options: <input type="checkbox"/> Protective tube (6) (total length + 5 mm)		06.010.00

Additional details: