

## Additional Options

This section provides information on additional options which enable you to employ gas springs in certain applications, or simply make them much easier to use.

The additional options suitable for each gas spring can be found in the data pages corresponding to each type of gas spring (starting on page 06.017.00).

Please pay attention to details concerning the different lengths of gas springs as some additional options increase the minimum length of the cylinder.

## Temperature, Corrosion

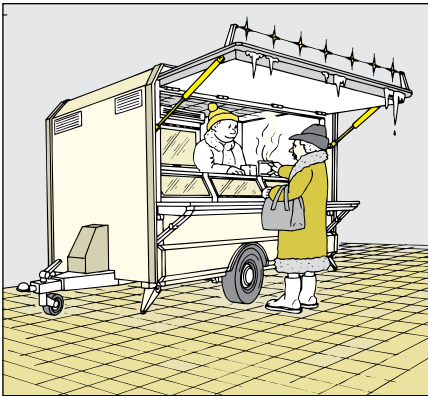

Gas springs are filled with nitrogen gas and hydraulic oil at approx. **20 °C**. Internal pressure and extending force decrease in low temperatures and increase in high temperatures. The force of the gas spring varies by approx. **1 %** for every **3 °C** difference in the filling temperature.

DICTATOR gas springs are designed for temperatures between **minus 10 °C and plus 80 °C**. DICTATOR gas springs can also be used from **minus 30 °C** if they have **special seals** and **special hydraulic oil**.

The seals can no longer be guaranteed to function perfectly in temperatures **above 80 °C**, so avoid using them near ovens, fire, heating and sun radiation behind glass.

Gas springs heat up when operating **quickly** and **frequently**, even at normal room temperature. So make sure they are not operated more than approx. 6 times per minute.

We are always prepared to carry out tests and advise you if you have an application with high stroke rates. We however recommend that you make an additional test of your application yourself.

If you intend to use gas springs outside, or in humid or aggressive conditions, we recommend our **stainless steel** gas springs. Details can be found starting on page 06.045.00.

## Progressivity

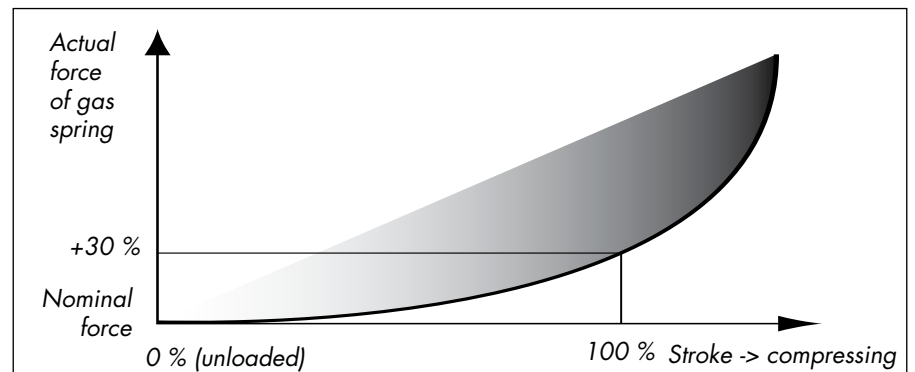
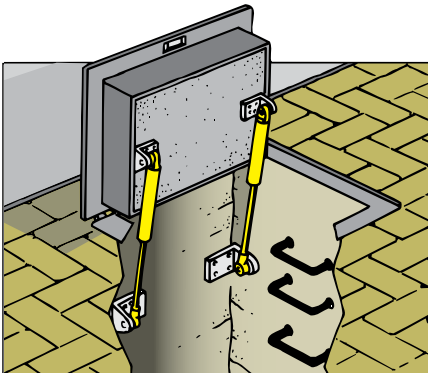

When the piston rod is pushed inside the cylinder there is less space available for the gas in the cylinder because the volume of the piston rod reduces the remaining volume inside which is occupied by the gas. Therefore, the gas pressure increases as the gas spring is compressed. This is called "progressivity of the gas spring". The increase in force usually amounts to approx. 30 % when the piston rod is completely compressed.

On request we can manufacture gas springs for you with a higher or lower progressivity to enable heavy hatchways to be lifted effortlessly.

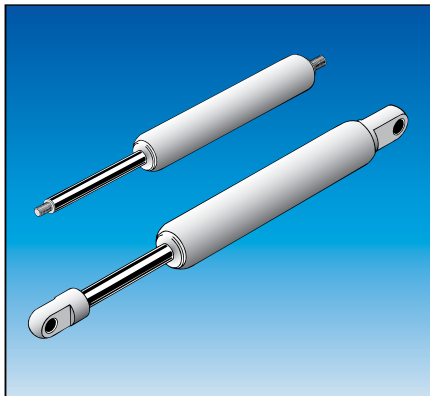

## Oil Chamber and Valve

These accessories enable DICTATOR gas springs to be used in conditions where normal gas springs would have little durability, or could only be adjusted to different forces at high cost.

Oil chambers (order code 4) and valves (order code 5) are available for most DICTATOR gas spring models. You will find further information in the detailed description of each type of gas spring starting on page 06.017.00.

### Oil Chamber (4)

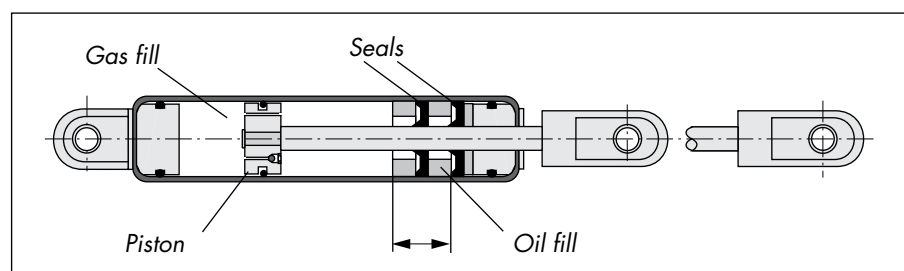
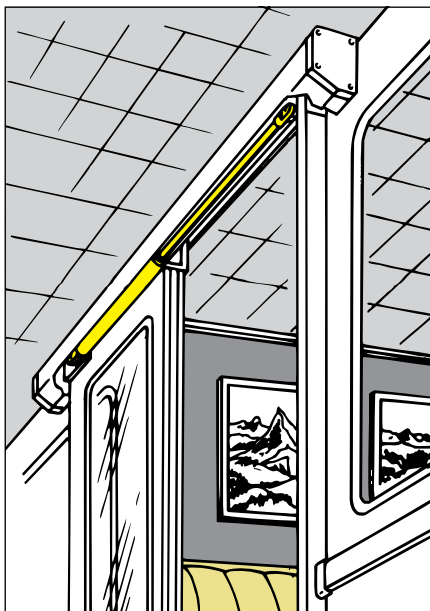

Virtually all DICTATOR gas springs are available with an additional oil chamber. This prevents the seal on the piston rod from drying out and failing. The oil also ensures easy sliding of the piston rod and reduces friction.

An oil chamber is always necessary when the gas spring is installed horizontally or when its normal position deviates by more than 30° from the vertical position. It is not necessary when the piston rod shows vertically down because then the oil in the cylinder always has direct contact to the seal anyway.

Please be aware that gas springs containing an oil chamber need a slightly longer cylinder. Exact additional measurements can be found on the pages concerning the individual models starting on page 06.017.00.

### Valve (5)

DICTATOR gas springs fitted with a valve allow you to decrease the gas pressure and reduce the extending force yourself.

It is best to order a gas spring with a valve if you are unsure of the exact force required or when you want to use gas springs of one batch to balance out different weights e.g. on different windows.

Gas springs fitted with a valve are also ideal when trying to find out the necessary force on a sample application. When you have adjusted to the force required, you can then return the gas spring to us. We will measure the exact force and produce the batch for you with cost-effective gas springs (without the valves) which match the required force.

In the detailed description of each gas spring in this brochure (beginning on page 06.017.00) we specify which gas spring models are available with valve.

Instructions for handling the valve are given on the following page 06.011.00 =>

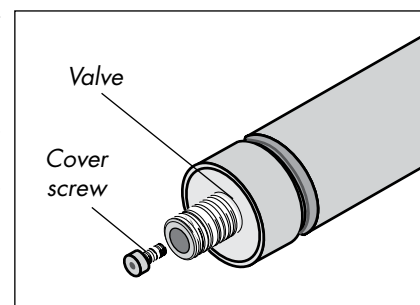

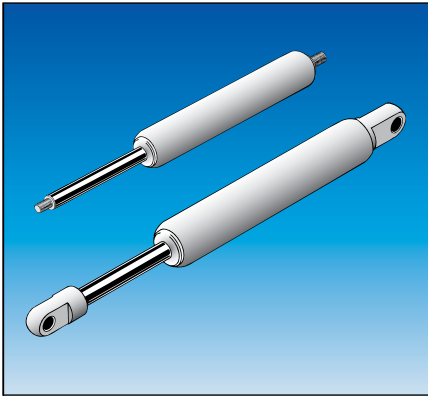

## Protective Tube

This accessory enables DICTATOR gas springs to be used even in particularly dirty or rough conditions e.g. on road sweepers and sand blast cabins.

If necessary an additional protective tube (double protective tube) can be fitted over the first protective tube.

Protective tubes (order code 6 or 9 for stainless steel) and double protective tubes (order code 6-6 or 9-9 for stainless steel) are available for most DICTATOR gas springs. Details can be found on pages 06.017.00 - 06.058.00 further back in this catalogue.

## Protective Tube (6) or (9)

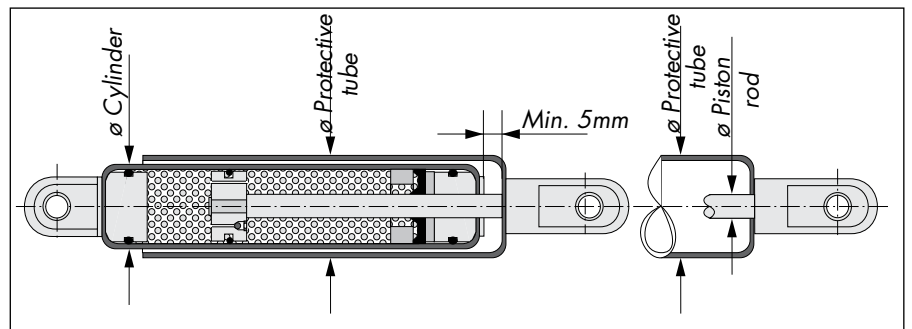
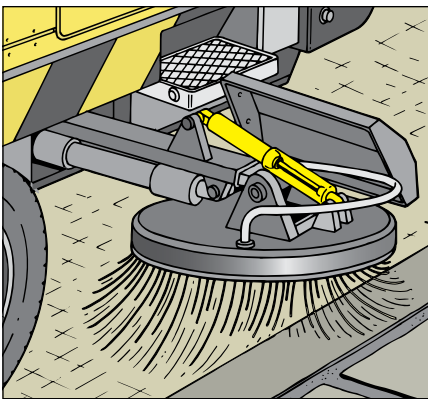

We recommend you order a protective tube when the gas spring is exposed to a high level of contamination. It also protects the piston rod from mechanical damage and therefore increases the operational life of all gas springs. Scratches, dust, dirt, paint or other damages to the surface of the piston rod cause the gas spring to wear prematurely and fail. The protection tube of AISI 304 stainless steel has the order code 9.

Please remember that gas springs have a 5 mm longer measurement per protective tube. Exact measurements can be found on pages 06.017.00 - 06.058.00.

## Handling the Valve

Using an Allan key, remove the socket set screw in the cylinder end fitting. Be careful not to loose the o-ring on this screw. (Some gas springs have a valve without this socket set screw).

Now place a pin (2,5 mm diameter; approx. 3/32") in the available hole. You could also simply use a nail with a blunt point. Hit the pin shortly with a small hammer (7 ounces/ 200 g). You should test the function of the gas spring(s) in your application after one or maximum 5 strikes.

If you reduce the pressure too much we can refill the gas spring in our factory and in other DICTATOR branches for a small charge.

**Important:** If the pressure has been reduced to 0, please make sure to screw a nut or eyelet on the piston rod in order to prevent the piston rod from disappearing completely inside the cylinder tube.

### **Attention: High gas pressure!**

**Protective glasses** must be worn when unscrewing the socket set screw and releasing the pressure. Should the release valve be damaged the socket set screw may be under **pressure** and once unscrewed the gas pressure could cause it to fly off suddenly. The **oil** in the cylinder could also spurt out. Therefore always hold the end of the gas spring with the valve facing upwards and away from you.

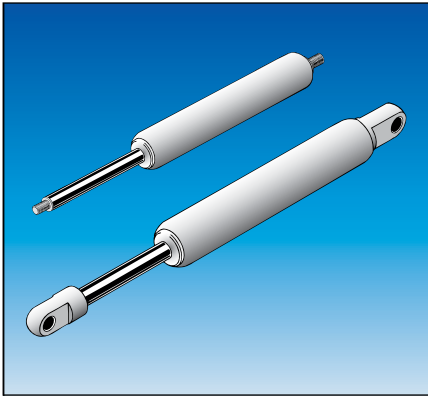

### Additional Helical Spring and Biological Oil

Dictator gas springs are equipped with reliable seals which allow for a particularly long life, without the gas pressure decreasing prematurely.

The pressurised gas inside the gas spring pushes the seal hard against the piston rod. This causes friction which considerably reduces the force of the gas spring, particularly when it starts moving again after a long static period.

This slip-stick effect can be reduced by using an oil chamber with hydraulic or biological oil (see page 06.010.00) and/or an additional helical spring.

### Additional Helical Spring

(7)

We recommend you order a Dictator gas spring with an additional helical spring if you want to automatically open a flap after releasing it. These spiral springs successfully overcome friction caused at the beginning, even after long rest periods.

The helical spring can be installed inside the gas spring cylinder or on the piston rod. Please use our Advisory Service to help select the most suitable products.

We will be happy to send you data regarding all available Dictator gas springs with helical springs on request.

These gas springs are most often used in automatically opening hatches and windows for emergency escape and smoke ventilation.

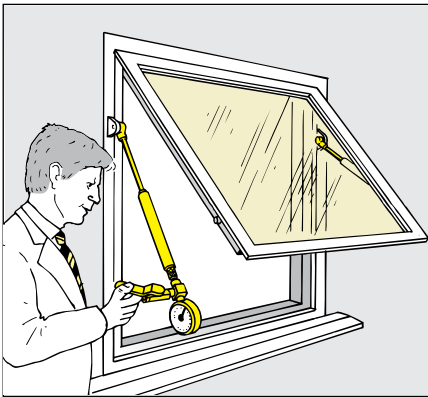

### Biological Oil

(8)

Environmentally friendly biological oil is based on rape seed oil and enables gas springs with damping to operate in areas where the use of mineral oil or synthetic oil based on silicone is not permitted e.g. in the food industry, in machines and factories which manufacture chemicals or paint and in the pharmaceutical industry.

Dictator gas springs and dampers which utilise biological oil have been subjected to extensive testing even in very high and very low temperatures.

We will be happy to send you detailed information regarding each type of oil on request.

These gas springs can be used from plus 60 °C (140 °F) to approx. minus 20 °C (minus 4 °F). When using them in extreme temperatures, please take note of the advice given regarding change in pressure on page 06.009.00.

Details concerning Dictator stainless steel gas springs (available with biological oil) can be found amongst the technical data on pages 06.045.00 - 06.058.00.

If required, the gas springs can also be furnished with FDA conform oil. This has to be indicated in addition to the code number 8.

