

AC-21 Sliding Door Operators

DICTAMAT 900-21

The DICTATOR **DICTAMAT 900-21** door operator series in combination with the SQUARE 940-2 control system complies with the **demands of the EN 12453 for the "Safety in use of power operated doors"**.

All door operators are equipped with a **mechanical brake** that assures the stop of the door within the required distance even without current. An integrated thermal cutout protects the operator from too high loads.

The position control is done either with **separate limit switches** or an **encoder**, integrated in the motor, that permits a very precise positioning.

Due to the mechanical brake the motor is blocked without current. If the door has to be moved by hand in case of a power failure an additional **mechanical cranking device** can be supplied.

DICTATOR gladly will offer you a solution taking into account the requirements of your individual application. Please ask for a detailed offer and if necessary, CAD-drawings.



Selection Criteria

- For doors up to 10 m (standard)
- Pulling forces from 370 N to 2200 N
- For doors up to max. 4000 kg
- For up to 300 cycles per day (depending on the weight of the door and the speed)
- Position control: integrated encoder or separate limit switches
- Motor blocked without current
- Control system: SQUARE 940-2
- Complies with the demands of EN 12453



Summary

The new AC-21 series is a consequent application of the modular system already used with the DC-21 series. The AC-21 series offers the possibility of powered operation also of extremely large and/or heavy doors according to the requirements of the EN 12453. The modular system permits individual, customised solutions for every door. All door operators are based on similar modules and are operated with the same control system.

The values in the table below are just for orientation and a preselection. They may differ considerably depending on the type and design of the door, additional standards and legal requirements valid for the respective site. Please ask for our technical support and our customised offer.

Technical Data

Type / Motor Rating	0.18 kW	0.18 kW	0.37 kW	0.55 kW
Force of the motor	370 N	630 N	1200 N	2200 N
Opening and closing speed	separately adjustable			
max. m/sec.	0.4	0.2	0.2	0.15
Voltage	230/400 VAC			
Nominal current pf the control system	8 A	8 A	8 A	8 A
Driving torque (at the axle of the operator)	14 Nm	24 Nm	61 Nm	150 Nm
Braking moment (mechanical brake)	4 Nm	4 Nm	5 Nm	10 Nm
Duty cycle	40 % ED			
IP rating	IP 55			
Weight (without accessories)	10 kg	10 kg	21 kg	40 kg
Doors up to*	600 kg*	1000 kg*	1500 kg*	4000 kg*
Travel	6 m	6 m	10 m	10 m

* The given weights are just reference values. The determining point is how easily the door moves.

Options

- Position control

The standard operator is designed for separate limit switches. The control system however identifies an additional Open position (partial opening) without an extra limit switch. The control system calculates this position - if adjusted once - from the final positions and the memorised travel.

The AC-21 door operators are also furnished with an integrated encoder.

- Mechanical brake

The standard AC-21 operators are equipped with a mechanical brake making sure that even in case of a power failure the door is stopped within the required distances. In case of doors to which the EN 12453 standard does not apply, the door operators can also be furnished without the mechanical brake.

- Mechanical cranking device (not possible with the 0.55 kW operators)

All door operators with integrated mechanical brake impede moving the door without current. If the doors have to be moved manually in case of a power failure, the following options are available: additional mechanical cranking device or electromagnetic clutch.

- Accessories

Due to the extremely high forces that occur upon the actuation of the mechanical brake extremely sturdy fixing brackets are required. As the door operator therefore normally cannot be fixed to the rail, we supply special brackets for fixing the door operator to the wall.



Components

The AC-21 door operators transmit the power to the door with the help of a revolving toothed belt. They are normally fixed to the wall, as the rails cannot take up the forces resulting from the action of the mechanical brake.

The following picture shows the components of a AC-21 door operator system for sliding doors.

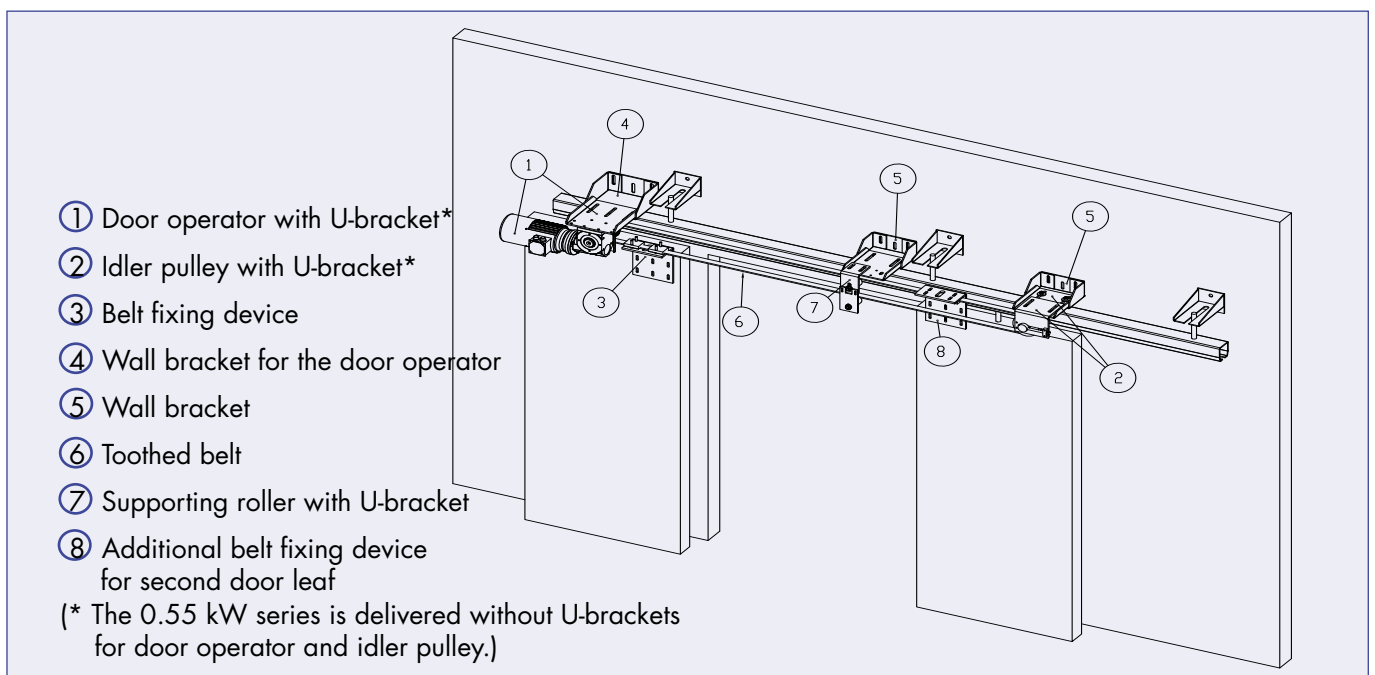

Components Included DICTAMAT 900-21

- Door operator: worm gear transmission with a 230/400 VAC three-phase motor and integrated mechanical brake, integrated thermal cutout, 2 m connection cable to the control system, driving wheel for toothed belt
- U-bracket for the door operator*
- Idler pulley for toothed belt with integrated tensioning device and U-bracket*
- Belt fixing device for the door

Additional Components

- Integrated encoder
- Mechanical cranking device
- Electromagnetic clutch

Separate Accessories

- Toothed belt (type depends on the motor)
- Wall bracket for the door operator
- Wall bracket for the idler pulley
- Supporting roller with U-bracket for the toothed belt
- Wall bracket for the supporting roller
- Additional belt fixing device for sliding doors with two leaves



DICTAMAT 900-21, 0.18 kW

The standard components of the DICTAMAT 900-21, 0.18 kW are besides the door operator with U-bracket the idler pulley for toothed belt with integrated tensioning device as well as the belt fixing device. The 0.18 kW door operator uses the HTD 8 toothed belt. The width (either 20 or 30 mm) depends on the weight of the door and the required speed.

The 0.18 kW door operator needs an especially designed idler pulley. The belt fixing device is used both for the 0.18 and 0.37 kW door operator.

Wall brackets for the door operator and the idler pulley are to be found on page 04.033.00.

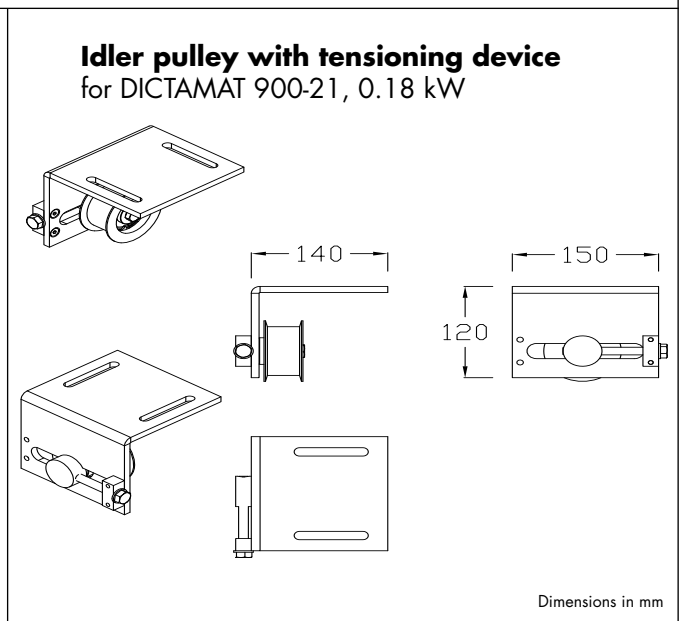
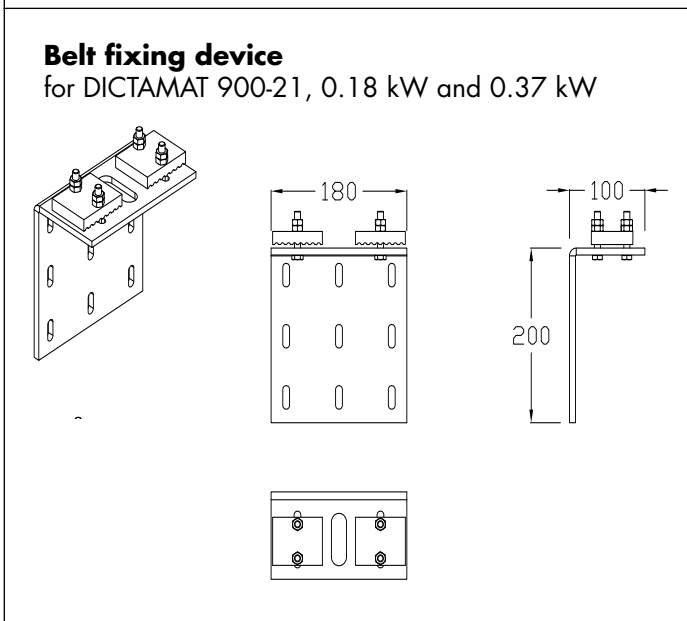
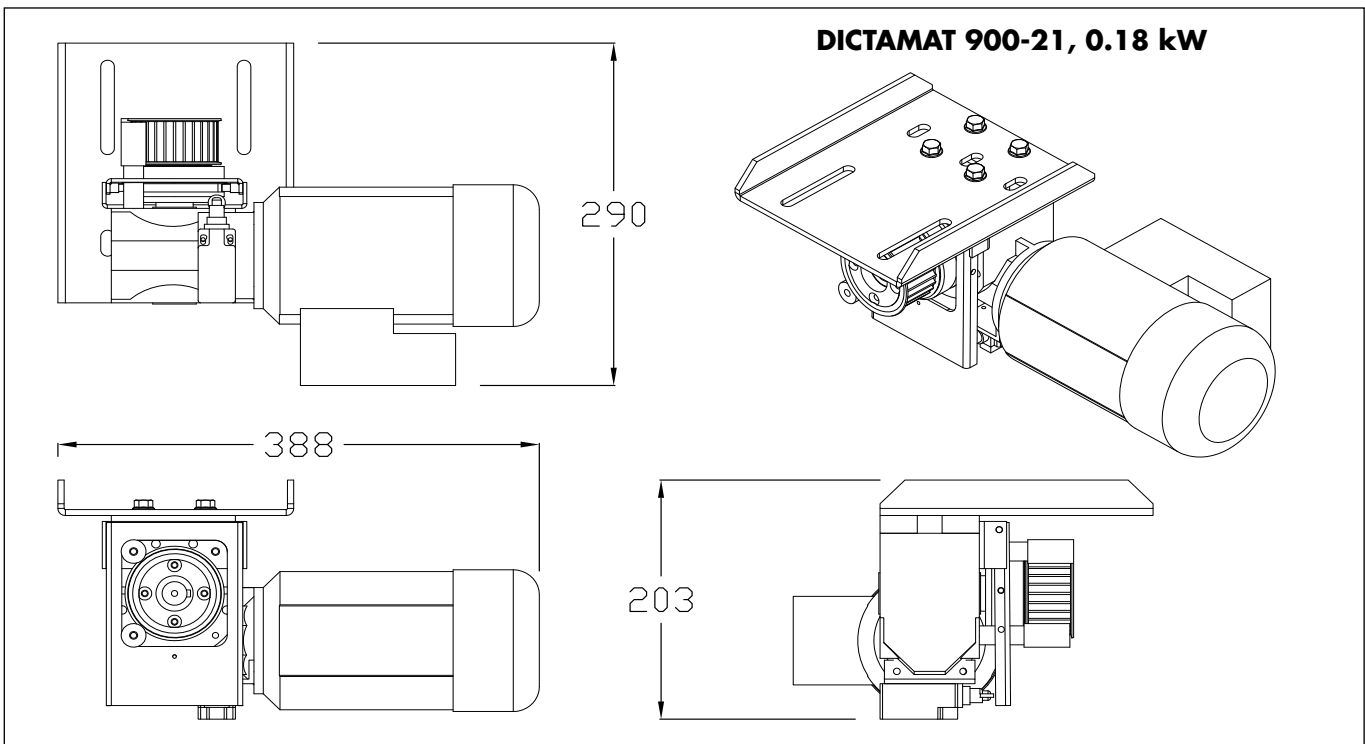

Dimensions in mm



DICTAMAT 900-21, 0.37 kW

The standard components of the DICTAMAT 900-21, 0.37 kW are besides the door operator with U-bracket the idler pulley for toothed belt with integrated tensioning device and U-bracket as well as the belt fixing device.

The 0.37 kW door operator uses the 30 mm wide HTD 8 toothed belt.

The 0.37 kW door operator needs an especially for this type designed idler pulley. The belt fixing device is used both for the 0.18 and 0.37 kW door operator.

Wall brackets for the door operator and the idler pulley are to be found on page 04.033.00.

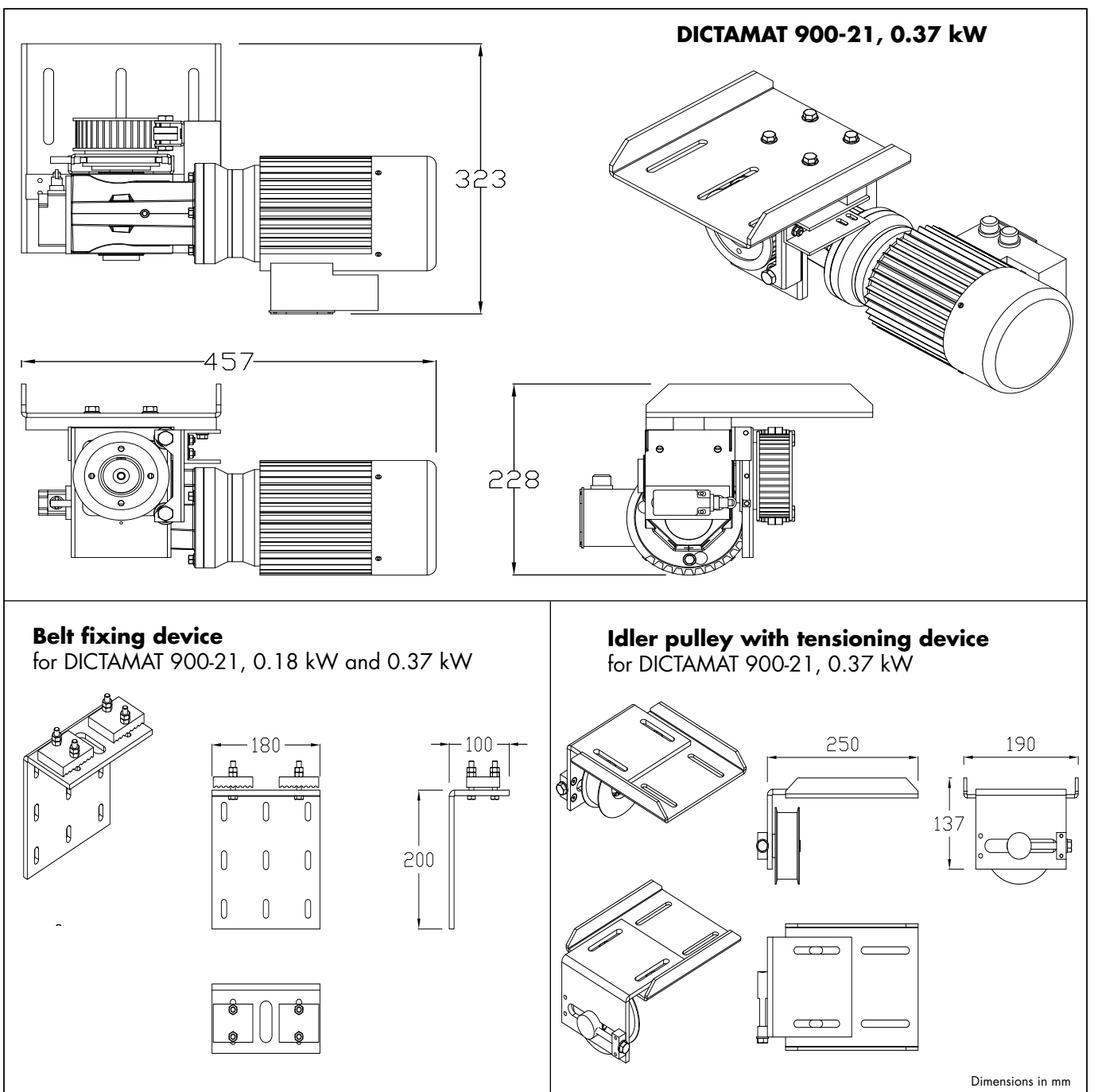



DICTAMAT 900-21, 0.55 kW

The standard components of the DICTAMAT 900-21, 0.55 kW are besides the door operator the idler pulley for toothed belt with integrated tensioning device as well as the belt fixing device. Due to the extremely high forces acting in case of the mechanical Emergency-Stop fixing brackets have to be designed individually for each application. The 0.55 kW door operator uses a 55 mm wide toothed belt.

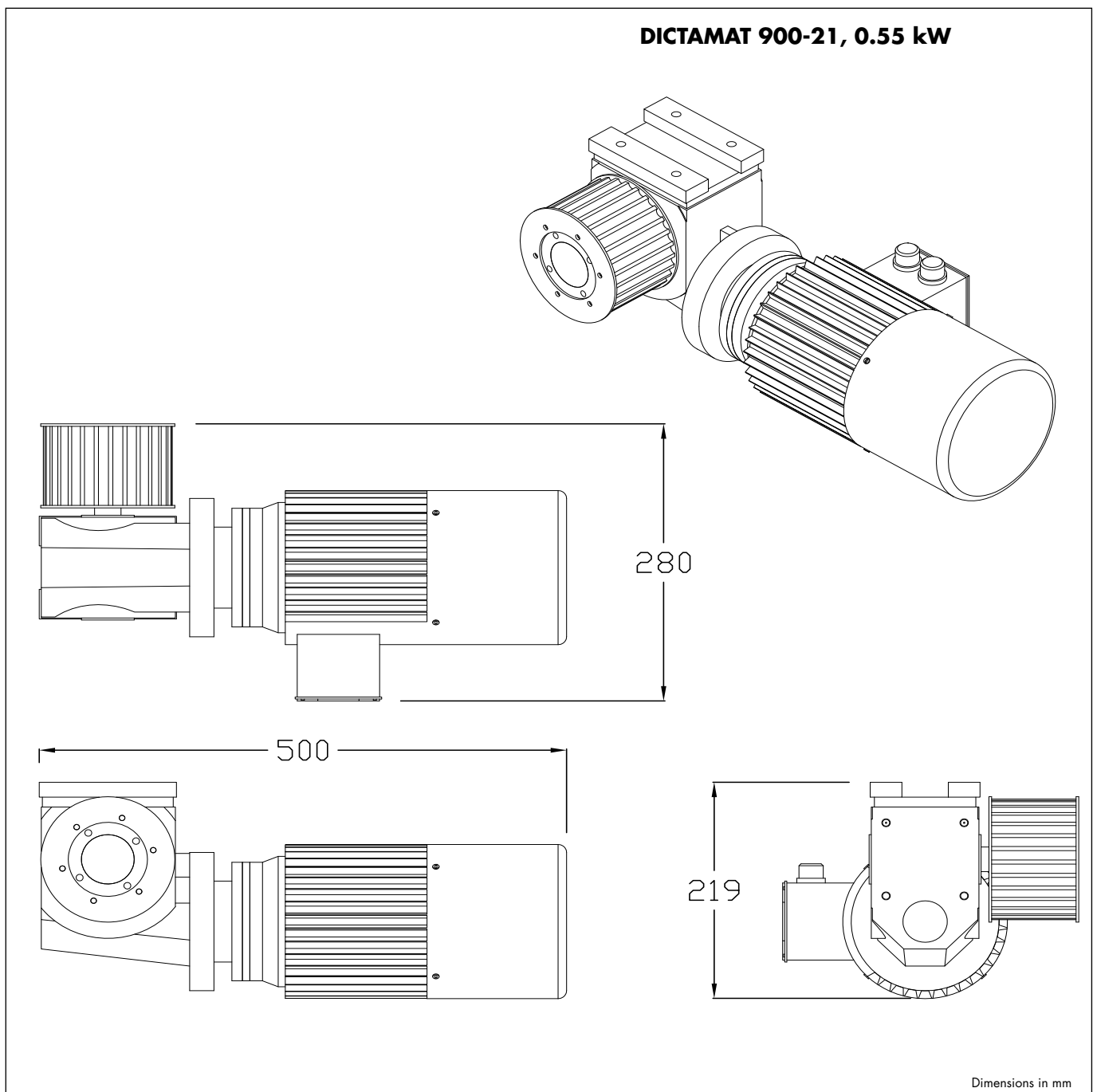



Accessories

In order to assure the necessary stability the DICTAMAT 900-21 door operators are normally fixed to the wall. There are special wall brackets available that are designed especially for the U-brackets delivered with the door drives and that withstand the high forces in case of an Emergency-Stop.

The wall must be sturdy enough to absorb the pull and shear forces. Furthermore special dowels for dynamic loads have to be used.

Wall Bracket 0.18 kW

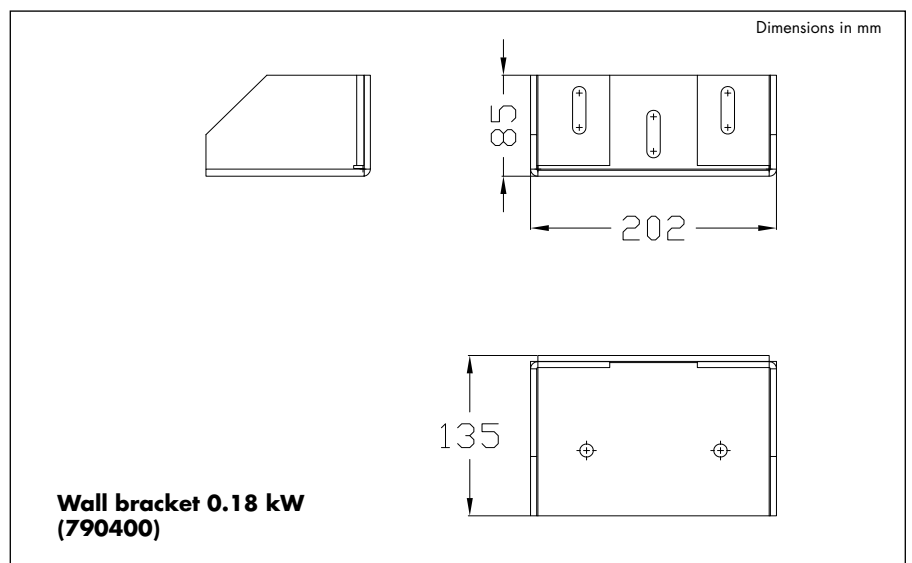
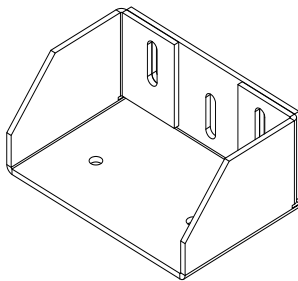

Use of the wall bracket 0.18 kW:

- DICTAMAT 900-21, 0.18 kW door operator
- Idler pulley with tensioning device for DICTAMAT 900-21 0.18 kW
- Idler pulley with tensioning device for DICTAMAT 900-21 0.37 kW
- Supporting roller for DICTAMAT 900-21 0.18 and 0.37 kW

Wall Bracket 0.37 kW

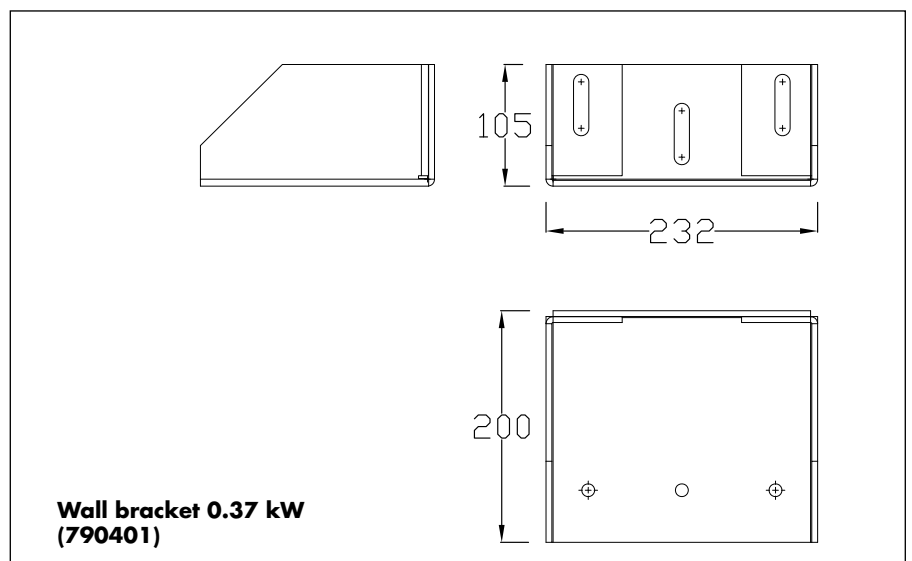
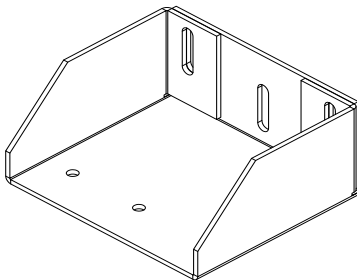

Use of the wall bracket 0.37 kW:

- DICTAMAT 900-21, 0.37 kW door operator



Accessories - continued

Some of the accessories can be used both for the 0.18 kW and 0.37 kW series. Among those are the supporting roller for the thoothed belt and the additional belt fixing device for doors with two leaves.

The supporting rollers prevent the sagging of the belt. They have to be used whenever the toothed belt would run unsupported for more than four meters. The rollers are generally furnished together with an U-bracket. An additional wall bracket is available (see preceding page).

In case of doors with two leaves an additional belt fixing device is required. It is always the upper part of the belt that is fixed to this device.

Supporting Roller for 20/30 mm Toothed Belt

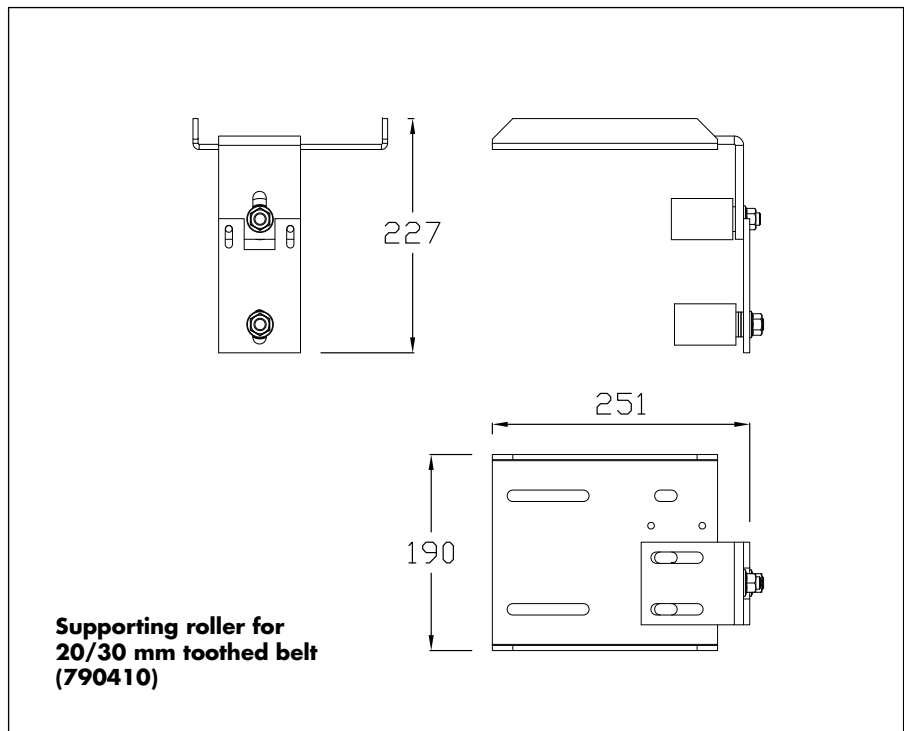
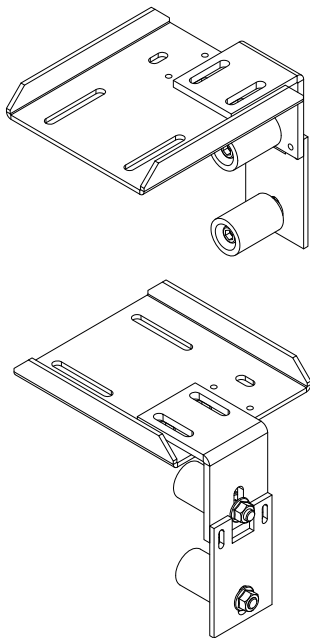

Belt Fixing Device for Doors with Two Leaves (20/30 mm Toothed Belt)

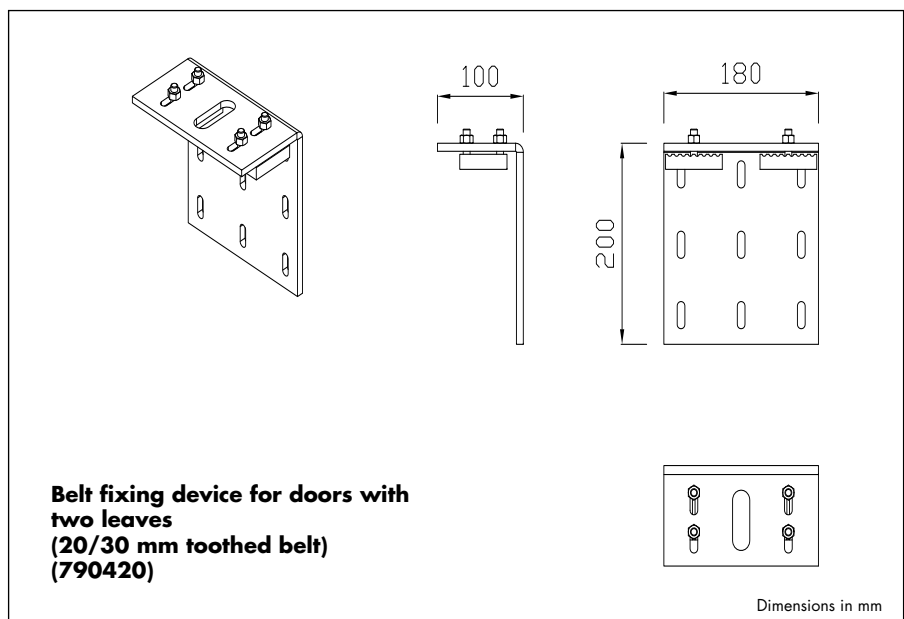
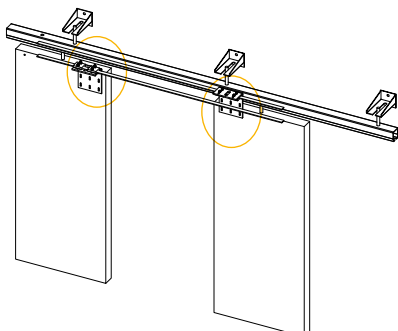



Accessories - continued

The power transmission of the AC-21 door operators is done with a toothed belt. There are different types, depending on the size of the door and the forces. The EN 12453 standard requirements result in a rather strong toothed belt for larger doors.

Toothed Belt

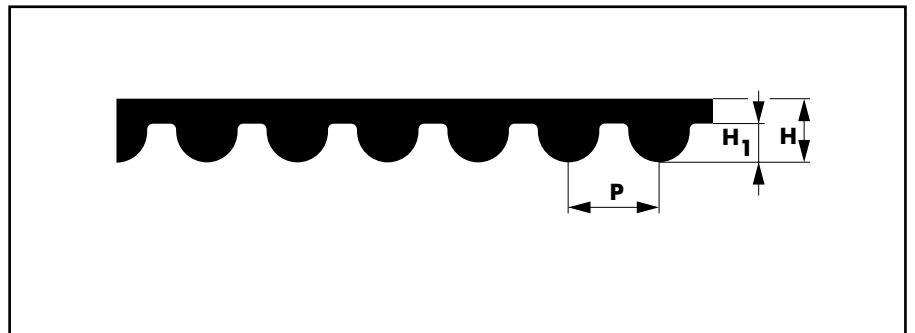

Technical Data

Type	HTD 8M	HTD 14M
P	8	14
H	5.6	10.6
H₁	3.4	6.1

Material	PU (polyurethane)	
Tensile material	steel cord	
Operating temperature	-30° to +80 °C	
Resistant against	UV, ozone, oil and grease	
Tension load:	- HTD 8M toothed belt, 20 mm wide	2680 N
	- HTD 8M toothed belt, 30 mm wide	4030 N
	- HTD 14M toothed belt, 55 mm wide	10930 N



Order Information

Below are listed the part numbers of the most common door operators. There is a much larger range of door operators available, e.g. with mechanical cranking device etc. Please contact us and ask for an offer for your application.

The components included in the delivery are listed on page 04.029.00. The meaning of the different letters and numbers is explained below.

Information on the SQUARE 940-2 control system and further components of a powered door installation as push buttons, safety equipment and limit switches are to be found later on in this chapter.

Order Information Door Operators

DICTAMAT 900-21 ZEB	0.18 - 0.4	part no. 790000
DICTAMAT 900-21 ZLB	0.18 - 0.4	part no. 790050
DICTAMAT 900-21 ZEB	0.18 - 0.2	part no. 790100
DICTAMAT 900-21 ZLB	0.18 - 0.2	part no. 790150
DICTAMAT 900-21 ZEB	0.37 - 0.2	part no. 790200
DICTAMAT 900-21 ZLB	0.37 - 0.2	part no. 790250
DICTAMAT 900-21 ZEB	0.55 - 0.15	part no. 790300
DICTAMAT 900-21 ZLB	0.55 - 0.15	part no. 790350

Order Information Accessories

Wall bracket 0.18 kW	part no. 790400
Wall bracket 0.37 kW	part no. 790401
Supporting roller for 20/30mm toothed belt	part no. 790410
Belt fixing device for doors with 2 leaves (20/30 mm toothed belt)	part no. 790420
HTD 8M toothed belt, 20 mm wide	part no. 710490
HTD 8M toothed belt, 30 mm wide	part no. 710491
HTD 14M toothed belt, 55 mm wide	part no. 710485

Order Information Control System

SQUARE 940-2 control system	part no. 706094-2
-----------------------------	-------------------

Information about the control system can be found beginning on page 04.037.00.

Legend:

Z	Power transmission by toothed belt
E	Position control with separate limit switches
L	Position control with integrated encoder
B	Mechanical brake
0.18 - 0.4	Motor 0.18 kW, speed 0.4 m/s