

DICTATOR Home Lift DHM 500

The Lift According to the Machinery Directive 2006/42/EC

Being mobile is one of the essentials of today's life. The DICTATOR home lift DHM 500 is the ideal solution both for installation in a house under construction or for retrofit into existing houses in order

- to facilitate daily life
- to enable people to stay in their own home when being old and/or physically handicapped.

The DHM 500 has been tested and approved by the TÜV Rheinland/Germany in accordance with the Machinery directive 2006/42/EC on the basis of the requirements of the standard EN 81-41.

Like many other DICTATOR products every homelift DHM 500 is a **bespoke installation being planned and manufactured individually**. This procedure often allows to install a lift even if the available space is most unfavourable. An additional advantage is the small depth of the pit of only 80 mm and that the headroom of 2500 mm in the top floor may be reduced under certain circumstances to only 2300 mm.

The DICTATOR DHM 500 can be installed either in a lift shaft provided by the customer or be furnished complete with a DICTATOR steel lift shaft.



Technical Data

Rated load	max. 500 kg
Cabin size	max. 2 m ²
Speed	max. 0.15 m/sec.
Travel	max. 14 m
Depth of pit/Headroom top floor	min. 80 mm/ca. 2500 mm (min. ca. 2300 mm)
Power supply	400 VAC/2.2 kW (standard), 230 VAC (surcharge)
Type of lift	1:2 roped hydraulic drive
Operation	depending on the furnishing, see next page



I. Technical Data / Features

Features

Compared to a normal lift (according to the lift standard) a lift according to the Machinery Directive has a few restrictions but also some important advantages.

Operation

A homelift is never intended for general use. It may only be used by persons who have been instructed to use it. For this purpose it is normally equipped with key switches so that only persons with a key can operate it. In the basic furnishing without cabin door the key of the desired floor has to be pressed during the whole travel. When reaching the chosen floor the lift stops on its own. When the key is released during the travel, the lift stops. This is to ensure the safety of the persons in the cabin.

In case the lift is called from one of the landings the key has to be pressed only shortly. To operate the lift also from inside the cabin **by impulsion** is always then possible if the cabin has **cabin door(s)**.

Speed

The maximum speed allowed for a homelift is 0.15 m/s. This relatively slow speed allows to do without cabin doors. This represents a big advantage if there is little space available.

Cabin

Every cabin of the homelift DHM 500 is **custom-built**. The dimensions don't have to exactly meet the regulations, not like a lift according to the lift standards, but are always manufactured to fit in the given space. The cabin of the DHM 500 can be made with access from one side, through cabin, from adjoining sides or from three sides. This allows to adapt it in an optimal way to the situation on site, especially when being retrofitted. The open cabin sides are secured by a light grid of the category II (standard). This means as soon as somebody triggers them the travel of the cabin is stopped. Apart from the open accesses the cabin of the DHM 500 is closed, i.e. it disposes of high walls and a ceiling.

Requirements of pit and headroom (dimensions see below)

Another advantage of the DHM 500, beside the customized cabins, are its minimal requirements concerning the dimensions of the pit (space below the lowest stopping place) and the headroom (height above topmost floor level).

Dimensions

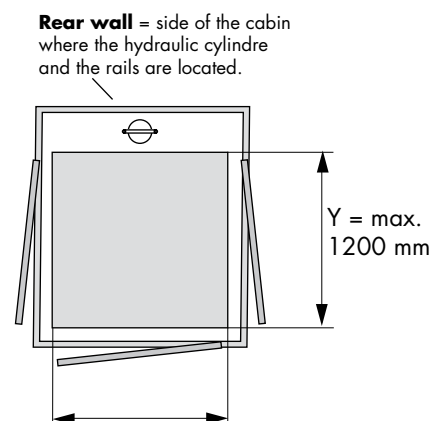

1. Cabin

- Floor space

In general the cabin measurements are chosen to the requirements of the client - taking into consideration the directives and the technical feasibility. Due to technical reasons measure Y (see drawing beside) may be max. 1200 mm.

- Cabin height

Standard	approx. 2035 mm or approx. 2085 mm
Minimum	1900 mm (allowed only in the private sector or when the edificial situation permits nothing else)

2. Shaft

- Pit

min. 80 mm (in case of standard dimensions and weights); recommended are 200 mm (necessary in case of large and/or heavy cabins, e.g. with glass wall)

- Headroom

2500 mm
may possibly be reduced to about 2300 mm

3. Hinged landing doors

Standard widths	500, 550, 600, 650, 700, 750, 800, 850, 900 mm
Clear heights	2000 mm (default); 1900, 2100 mm

4. Automatic sliding doors for landing and cabin doors (optional)

Standard widths	700, 800, 900 mm
-----------------	------------------

II. Furnishing / Delivery

Cabin Furnishing



Components Included or Available

<i>Mirror:</i>	Standard (half the height of the cabin) on one cabin wall
<i>Walls:</i>	Melamine panels, glass or stainless steel at an extra charge
<i>Floor:</i>	Anti-slip linoleum floor On request also prepared for floor by customers Skirting made of stainless steel
<i>Operating controls:</i>	Horizontal panel of stainless steel with push buttons (Ø 30 mm) in the cabin wall in front of the rails (one button per landing, one alarm button, one stop button and one key switch)
<i>Cabin lighting:</i>	Fluorescent tubes or LED lights in the cabin ceiling (white, black or stainless steel/at extra charge) The lighting is turned on automatically as soon as the landing door is opened and will be alight as long as the lift is in function. Then it will be switched off automatically (time adjustable between 8 and 30 seconds). In case of a power failure an emergency light is automatically turned on.
<i>Hand rail:</i>	at an extra charge: chromeplated or in stainless steel Special executions on demand

1) Standard equipment of the DHM 500 lift

Cabin with walls and ceiling, interior furnishing see above, telephone (feeding cable to be supplied by customer)

Rails pre-assembled to crossbar (standard length of the rail pieces 2.50 m),

Hydraulic cylinder with pipe rupture valve, hydraulic unit with valve block, shut-off valve, manometer, hand pump, emergency descent switch, 4 m hydraulic hose

Control system including distribution box on cabin roof with emergency stop button, retiring cam(s), ribbon cable, cable loom for the shaft wiring, position detector, magnets, emergency bypass switch, reset switch, floating battery for emergency descent, alarm and emergency lighting

Landing doors standard version: primary coat, with DICTATOR door damper, closing spring, door handle, narrow wire-reinforced glass pane, control panel in the door frame, emergency unlocking with additional safety contact, door locking and door contact

Safety features:

- safety light grid of category II according to EN in the cabin openings
- mechanical gripping device on both rails
- integrated testing device for the gripping device
- pipe rupture valve
- emergency descent device, hand pump
- automatic emergency lighting in the cabin
- alarm siren and telephone
- safety prop in the pit with device for folding out and folding to be operated from outside the shaft, integrated safety contact

2) Additional equipment

Cupboard for hydraulic unit and control system
(if there is no lockable machine room on site)

Intercom, when machine room/cupboard is not within calling distance

Non-standard design landing doors (see following page)

Electric door operator for landing doors

Cabin doors, non-standard furnishings for the cabin

III. Landing Doors - DICTATOR Lift Shaft System

Landing Doors

By default the landing doors of the DHM 500 are hinged doors. The following **dimensions** are available:

Width: 500, 550, 600, 650, 700, 750, 800, 850, 900 mm
(other dimensions upon request)

Height: 2000 mm (default)
1900 or 2100 mm on demand

Components of delivery (default):

- semi-automatic hinged door with primary coat, with closing spring and Standard door damper
- electromagnetic retiring cam and emergency unlocking
- wire-reinforced glass pane and door handle
- control panel in the door frame with call button and key switch



Non-standard design landing doors can be supplied at an extra charge with large window (in case of a 900 mm wide door: 575 mm x 1299 mm), powder-coated

and for exterior use corrosion protected and powder-coated. The doors can also be furnished with a door look and inside turning handle to prevent unauthorised persons from entering the cabin.

An optional possibility are **automatic sliding** (landing) **doors** or **folding doors** in the cabin.

DICTATOR Lift Shaft System

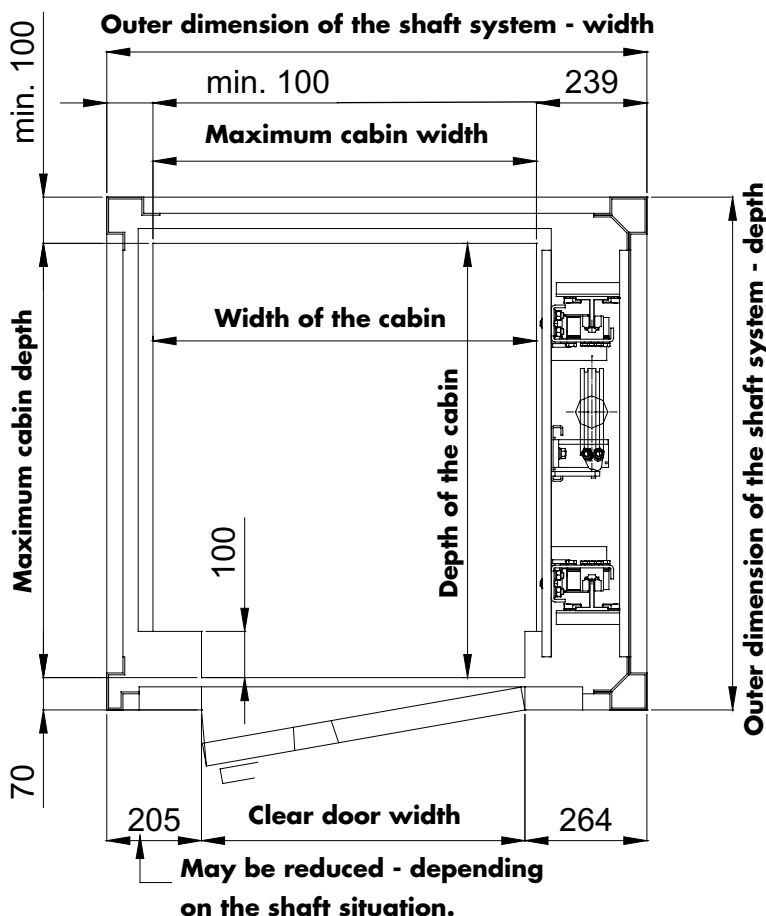

The DICTATOR lift shaft system **certified according to EN 1090** offers important advantages due to its modular structure, the elements all screwed together and its great flexibility. The design and production of the DICTATOR lift shaft system is bespoke. Therefore no fixed dimensions exist. The dimensions indicated in the drawing are just an indication for any calculation. It enables you to approximately determine the space required for the shaft with a determined cabin size or what cabin size might be achieved with given lift shaft dimensions. In case of complicated requests please contact our technical support.

Further detailed information is to be found starting on page 01.013.00.

Minimum dimensions of the Standard lift shaft with the hydraulic unit placed laterally:

The *minimum width* of the lift shaft is determined either by the desired cabin width or by the required width of the door (see drawing).

The *minimum depth* of the standard lift shaft is 1110 mm, being determined by the rail system. Depending on the door or shaft situation, this measure may be reduced.

Special designs with smaller dimensions can be realized on demand. Please ask us!

IV. Realized Projects DHM 500 - Examples

Homelift DHM 500 in a Very Narrow Stair Well - with Folding Door

For retrofitting a DHM 500 in an existing stair well a home lift with shaft system has been designed exactly to the given dimensions.

In spite of the very little given space there also could be realized the cabin door wanted by the customer. This allows to operate the cabin by impulsion instead of the standard dead man operation, i.e. the button of the desired floor has to be pressed just shortly.

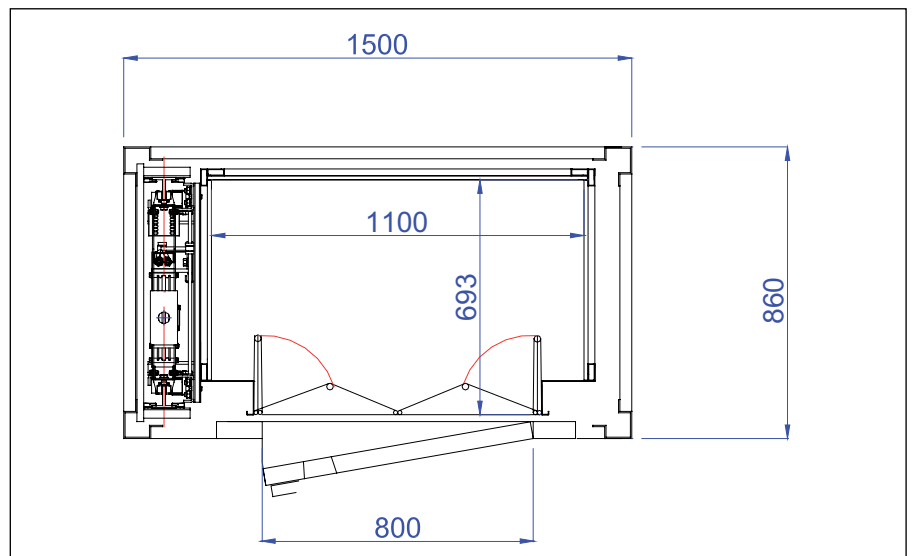

Homelift DHM 500 in an Extremely Narrow Stair Well with Glass Cabin Walls

Despite the extremely little depth of this stair well (860 mm!) the customer wanted a cabin with glass walls. As a shaft was used the DICTATOR lift shaft system with glass panels to keep the staircase as "open" and bright as possible.

To achieve the necessary stability this lift was provided with a third guide rail.

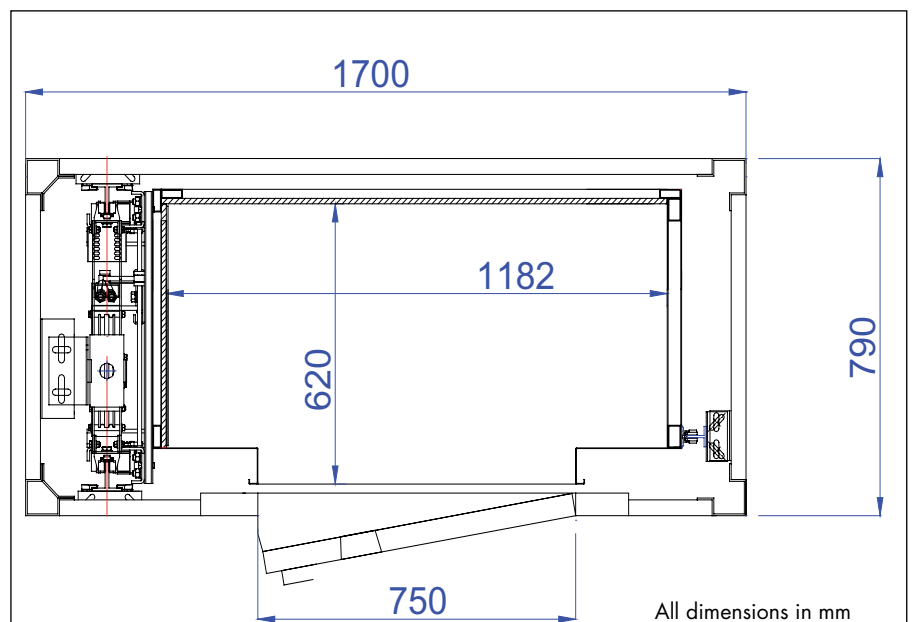

IV. Realized Projects DHM 500 - Cont. Examples

Homelift DHM 500 with 2 sqm Ground Area and 500 kg Load

Due to its robust concept and the high stability of its supporting frame the Homelift DHM 500 has been approved for loads up to 500 kg at a ground area of up to 2 sqm. In this case the Homelift also had been furnished with automatic doors to offer highest operating comfort.

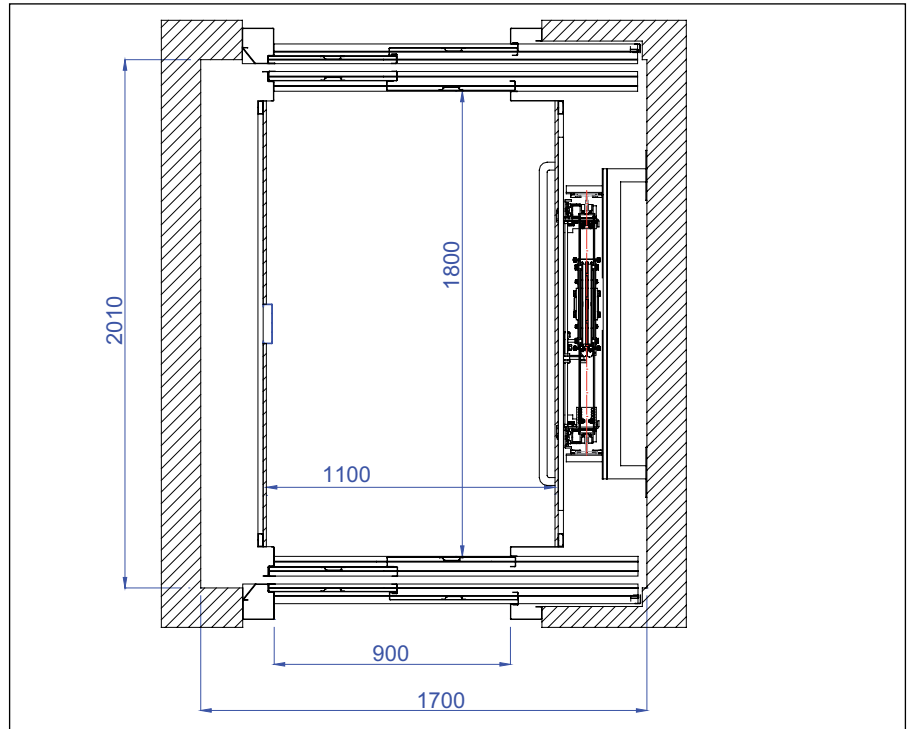

Homelift DHM 500 in a Triangular Stair Well

The following example demonstrates the extremely high flexibility of the DICTATOR Homelift DHM 500 and the lift shaft system. In order to realize in the triangular stair well a cabin with sufficient space the shaft system as well as the cabin were designed and manufactured in a pentagonal layout.

